



MAX17100 Evaluation Kit

Evaluates: MAX17100

General Description

The MAX17100 evaluation kit (EV kit) is a fully assembled and tested surface-mount PCB that provides the voltages and features required for active-matrix, thin-film transistor (TFT), liquid-crystal displays (LCDs). The EV kit contains a high-voltage step-up switching regulator, four high-current op amps, two linear regulators, two high-voltage switching blocks for gate-driver supply modulation, a digitally adjustable VCOM calibrator, and six independent scan drivers.

The EV kit operates from a DC supply voltage of 2.5V to 5.5V. The step-up switching regulator is configured for a +14V output that provides at least 500mA with an input voltage of 4.5V to 5.5V. The positive linear regulator is configured for a +25V output providing at least 20mA. The negative linear regulator is configured for a -10V output providing at least 20mA. The VCOM op amp is configured for 7V, capable of providing up to ± 200 mA peak current. The high-voltage, level-shifting scan driver buffers six logic inputs and shifts them to a desired level to drive TFT-LCD row logic.

The MAX17100 EV kit provides an on-board I²C interface that can be connected to a host computer through the universal serial bus (USB) port. The EV kit includes Windows® 2000-, Windows XP®, and Windows Vista®-compatible software that provides a graphical user interface (GUI) for control of the MAX17100's programmable features.

Features

- ◆ 2.5V to 5.5V Input Range
- ◆ 4.5V to 5.5V for Full Output Power
- ◆ 1.2MHz Step-Up Switching Frequency
- ◆ Output Voltages
 - +14V Output at 500mA (Step-Up Switching Regulator)
 - +25V Output at 20mA (Positive Linear Regulator)
 - 10V Output at 20mA (Negative Linear Regulator)
 - ± 200 mA High-Current Op-Amp Output
- ◆ Resistor-Adjustable Switching Regulator and Op-Amp Output Range
- ◆ Digitally Programmable Op-Amp Output Voltage
- ◆ +35V to -15V High-Voltage Level-Shifting Drivers
- ◆ > 85% Efficiency (Step-Up Switching Regulator)
- ◆ On-Board I²C Interface Control Through USB
- ◆ Windows 2000-, Windows XP-, and Windows Vista (32-Bit)-Compatible Software
- ◆ Lead(Pb)-Free and RoHS Compliant
- ◆ Fully Assembled and Tested

Ordering Information

PART	TYPE
MAX17100EVKIT+	EV Kit

+Denotes lead(Pb)-free and RoHS compliant.

Component List

DESIGNATION	QTY	DESCRIPTION
C1, C5	2	10 μ F $\pm 20\%$, 6.3V X5R ceramic capacitors (0603) Murata GRM188R60J106M TDK C1608X5R0J106K
C2, C3, C8, C27	0	Not installed, ceramic capacitors (0603)
C4, C6	2	2.2 μ F $\pm 20\%$, 6.3V X5R ceramic capacitors (0603) Murata GRM188R60J225K TDK C1608X5R0J225M

DESIGNATION	QTY	DESCRIPTION
C7, C13	2	1 μ F $\pm 10\%$, 6.3V X5R ceramic capacitors (0402) Murata GRM155R60J105K TDK C1005X5R0J105K
C9	1	220pF $\pm 10\%$, 50V X7R ceramic capacitor (0402) Murata GRM155R71H221K Taiyo Yuden UMK105BJ221KW

Windows, Windows XP, and Windows Vista are registered trademarks of Microsoft Corp.



Maxim Integrated Products 1

For pricing, delivery, and ordering information, please contact Maxim Direct at 1-888-629-4642, or visit Maxim's website at www.maxim-ic.com.

MAX17100 Evaluation Kit

Component List (continued)

DESIGNATION	QTY	DESCRIPTION
C10, C56	2	0.033 μ F \pm 10%, 16V X5R ceramic capacitors (0603) Murata GRM188R71C333K Taiyo Yuden EMK107BJ333KA
C11, C12, C16, C17, C28, C29, C41, C48–C53, C57	14	0.1 μ F \pm 10%, 50V X7R ceramic capacitors (0603) Murata GRM188R71H104K TDK C1608X7R1H104K
C14	1	0.22 μ F \pm 10%, 6.3V X5R ceramic capacitor (0402) Murata GRM155R60J224K TDK C1005X5R0J224K
C15	1	0.22 μ F \pm 10%, 25V X7R ceramic capacitor (0603) Murata GRM188R71E224K TDK C1608X7R1E224K
C18, C19	2	10 μ F \pm 20%, 25V X5R ceramic capacitors (1206) Murata GRM31CR61E106K TDK C3216X5R1E106M
C20–C25	6	100pF \pm 5%, 50V C0G ceramic capacitors (0402) Murata GRM1555C1H101J TDK C1005C0G1H101J
C26	0	Not installed, ceramic capacitor (1206)
C30	0	Not installed, through-hole OSCON capacitor (OSCON-B)
C31	1	0.01 μ F \pm 20%, 25V X7R ceramic capacitor (0402) Murata GRM155R71E103K TDK C1005X7R1E103K
C32	1	0.33 μ F \pm 10%, 50V X7R ceramic capacitor (0805) Murata GRM219R71H334K TDK C2012X7R1H334K
C33	1	0.47 μ F \pm 10%, 25V X5R ceramic capacitor (0603) Murata GRM188R71E474K TDK C1608X5R1E474K
C36–C39, C42, C44	6	1 μ F \pm 10%, 16V X7R ceramic capacitors (0603) Murata GRM188R71C105K TDK C1608X5R1C105K

DESIGNATION	QTY	DESCRIPTION
C40, C43, C45	3	10 μ F \pm 10%, 16V X5R ceramic capacitors (0805) KEMET C0805C106K4PACTU
C46, C47	2	22pF \pm 5%, 50V C0G ceramic capacitors (0603) Murata GRM1885C1H220J or TDK C1608C0G1H220J
C54, C55	2	10pF \pm 5%, 50V C0G ceramic capacitors (0603) Murata GRM1885C1H100J TDK C1608C0G1H100J
C66–C71	6	4700pF \pm 10%, 50V X7R ceramic capacitors (0402) Murata GRM155R71H472K TDK C1005X7R1H472K
D1	1	3A, 30V Schottky diode (M-Flat) Toshiba CMS01 Toshiba CMS02
D2, D3	2	200mA, 100V dual diodes (SOT23) Fairchild MMBD4148SE (Top Mark: D4) Central Semi CMPD7000 Lead Free (Top Mark: C5C)
D4	1	3A, 30V diode (SMA) Diodes, Inc. B350A-13-F Vishay B350A
D5	1	Not installed, 10V diode (SMA)
H1	0	Not installed, 2 x 5-pin JTAG header
JU1	1	Not installed, 2-pin header—shorted by PCB
JU2, JU6–JU11, JU14–JU19	13	3-pin headers
JU12, JU13	0	Not installed, 2-pin headers
L1	1	3.0 μ H, 3A inductor Sumida CDRH6D28-3R0
L2	1	Ferrite bead (0603) TDK MMZ1608R301A Murata BLM18SG700 TN1
P1	1	USB type-B right-angle PC-mount receptacle
Q1	1	200mA, 40V pnp transistor (SOT23) Fairchild MMBT3906_NL Diodes, Inc. MMBT3906-7-F

MAX17100 Evaluation Kit

Component List (continued)

DESIGNATION	QTY	DESCRIPTION
Q2	1	200mA, 40V npn transistor (SOT23) Fairchild MMBT3904 (Top Mark: 1A) Central Semi CMPT3094 Lead Free (Top Mark: C14)
Q3	1	-20V, 0.063Ω p-channel MOSFET (SC70 PowerPAK) Vishay SiA443DJ Vishay SiA411DJ
R1, R28–R31, R48, R55	7	100kΩ ±1% resistors (0402)
R2, R8, R32, R33, R34	0	Not installed, resistors (0603)
R3	1	180kΩ ±5% resistor (0402)
R4, R7	2	1kΩ ±5% resistors (0402)
R5, R6, R36	3	100kΩ ±1% resistors (0603)
R9–R14	6	100kΩ ±5% resistors (0402)
R15, R16	2	5.6kΩ ±5% resistors (0603)
R17	1	100kΩ ±5% resistor (0603)
R18, R24	2	6.8kΩ ±5% resistors (0603)
R19	1	191kΩ ±1% resistor (0402)
R20	1	10kΩ ±1% resistor (0402)
R21	1	27kΩ ±5% resistor (0603)
R22		31.6kΩ ±1% resistor (0402)
R23	1	324kΩ ±1% resistor (0402)
R25	1	24.9kΩ ±1% resistor (0402)
R26, R27	2	200kΩ ±1% resistors (0402)
R35	1	169kΩ ±1% resistor (0603)
R37, R38	2	27Ω ±5% resistors (0603)
R39	1	1.5kΩ ±5% resistor (0603)
R40	1	2.2kΩ ±5% resistor (0603)
R41	1	470Ω ±5% resistor (0603)
R42	1	10kΩ ±5% resistor (0603)
R43–R47	0	Not installed, resistors—shorted by PCB trace (0402)

DESIGNATION	QTY	DESCRIPTION
R49–R54, R61–R66	12	100Ω ±5% resistors (1206)
R56	1	137kΩ ±1% resistor (0402)
R57	1	13.3kΩ ±1% resistor (0402)
R58, R59, R60	3	0Ω resistors (0603)
SW1	1	6-position low-profile surface-mount DIP switch
U1	1	Internal-switch boost regulator (48 TQFN-EP*) Maxim MAX17100ETM+
U2	1	Microcontroller (68 QFN-EP*) Maxim MAXQ2000-RAX+
U3	1	2.5V LDO regulator (5 SO70) Maxim MAX8511EXK25+
U4	1	Adjustable output LDO regulator (5 SC70) Maxim MAX8512EXK+
U5	1	UART-to-USB converter (32 TQFP, 7mm x 7mm) FTDI FT232BL
U6	1	93C46A type (64k x 16) 3-wire EEPROM (8 SO) Atmel AT93C46EN-SH-B
U7, U8	2	Logic-level translators (10 μMAX®) Maxim MAX1840EUB+
U9	1	3.3V LDO (5 SOT23) Maxim MAX8887EZX33+ (Top Mark: ADPZ)
Y1	1	16MHz crystal
Y2	1	6MHz crystal
—	13	Shunts Digi-Key S9000-ND or equivalent
—	1	PCB: MAX17100 EVALUATION KIT+

*EP = Exposed pad.

Evaluates: MAX17100

μMAX is a registered trademark of Maxim Integrated Products, Inc.

MAX17100 Evaluation Kit

Component Suppliers

SUPPLIER	PHONE	WEBSITE
Central Semiconductor Corp.	631-435-1110	www.centalsemi.com
Diodes, Inc.	805-446-4800	www.diodes.com
Fairchild Semiconductor	888-522-5372	www.fairchildsemi.com
KEMET Corp.	864-963-6300	www.kemet.com
Murata Electronics North America, Inc.	770-436-1300	www.murata-northamerica.com
Sumida Corp.	847-545-6700	www.sumida.com
Taiyo Yuden	800-348-2496	www.t-yuden.com
TDK Corp.	847-803-6100	www.component.tdk.com
Toshiba America Electronic Components, Inc.	949-623-2900	www.toshiba.com/taec
Vishay	402-563-6866	www.vishay.com

Note: Indicate that you are using the MAX17100 when contacting these component suppliers.

MAX17100 EV Kit Files

FILE	DESCRIPTION
INSTALL.EXE	Installs the EV kit files on your computer
MAX17100.EXE	Application program
FTD2XX.INF	USB device driver file
UNINST.INI	Uninstalls the EV kit software
TROUBLESHOOTING_USB.PDF	USB driver installation help file

Quick Start

Recommended Equipment

- 2.5V to 5.5V, 3A DC power supply
- User-supplied Windows 2000, Windows XP, or Windows Vista PC with a spare USB port
- Voltmeter

Note: In the following sections, software-related items are identified by bolding. Text in **bold** refers to items directly from the EV kit software. Text in **bold and underlined** refers to items from the Windows operating system.

Procedure

The MAX17100 EV kit is fully assembled and tested. Follow the steps below to verify board operation.
Caution: Do not turn on the power supply until all connections are completed.

- 1) Verify that a shunt is installed across pins 2-3 of jumper JU2.

- 2) Connect the positive terminal of the power supply to the VS pad. Connect the negative terminal of the power supply to the PGND pad closest to VS.
- 3) Turn on the power supply and verify that the step-up switching regulator output (VMAIN) is +14V.
- 4) Verify that the positive linear regulator supply (VGHON) is approximately +25V.
- 5) Verify that the negative linear regulator supply (VGOFF) is approximately -10V.
- 6) Visit www.maxim-ic.com/evkitsoftware to download the latest version of the MAX17100 EV kit software, MAX17100Rxx.ZIP. Save the EV kit software to a temporary folder and uncompress the ZIP file.
- 7) Install the EV kit software on your computer by running the INSTALL.EXE program inside the temporary folder. The program files are copied and icons are created in the Windows **Start | Programs** menu.
- 8) Connect the USB cable from the PC to the EV kit board. A **Building Driver Database** window pops

MAX17100 Evaluation Kit

Evaluates: MAX17100

up in addition to a **New Hardware Found** message when installing the USB driver for the first time. If you do not see a window that is similar to the one described above after 30s, remove the USB cable from the board and reconnect it. Administrator privileges are required to install the USB device driver on Windows 2000, Windows XP, and Windows Vista.

- 9) Follow the directions of the **Add New Hardware Wizard** to install the USB device driver. Choose the **Search for the best driver for your device** option. Specify the location of the device driver to be **C:\Program Files\MAX17100** (default installation directory) using the **Browse** button. During device driver installation, Windows may show a warning message indicating that the device driver Maxim uses does not contain a digital signature. This is not an error condition and it is safe to proceed with installation. Refer to the TROUBLESHOOTING_USB.PDF document included with the software for additional information.
- 10) Start the MAX17100 EV kit software by opening its icon in the **Start | Programs** menu.
- 11) Normal device operation is verified when **MAX17100 Device Connected** is displayed in the status bar on the MAX17100 EV kit main window (Figure 1).

- 12) Verify that the output of the high-speed op amp (VCOM) is approximately 4V.

Detailed Description of Hardware

The MAX17100 EV kit contains a high-voltage step-up switching regulator, four high-current op amps, two linear regulators, two MLG blocks for gate-driver supply modulation, a digitally adjustable VCOM calibrator, and six independent scan drivers. The EV kit operates from a DC power supply between 2.5V and 5.5V that provides at least 3A.

As configured, the step-up switching regulator (VMAN) generates a +14V output and provides at least 500mA with input voltage of 4.5V to 5.5V. The step-up switching-regulator output voltage can be adjusted up to 18V with different feedback resistors (see the *Output-Voltage Selection* section). Jumper JU1 is provided for current measurement.

The op-amp output (VCOM) is set to 7V and can source or sink peak current up to 200mA. The output can be reconfigured to other voltages with voltage-divider resistors (see the *Output-Voltage Selection* section).

The six logic-level to high-voltage level-shifting buffers can buffer six logic inputs and shift them to a desired level to drive TFT-LCD row logic. The buffers' output is connected to GOFF when their respective input is

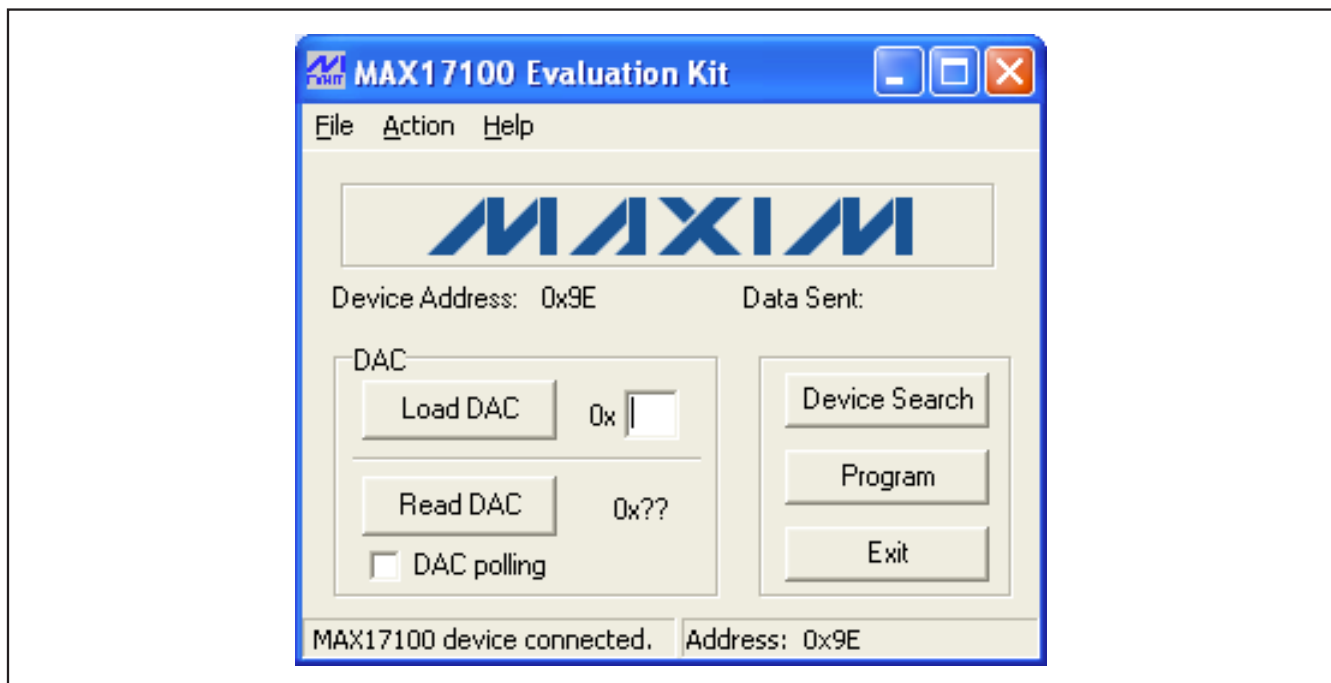

Figure 1. MAX17100 EV Kit Software Main Window

MAX17100 Evaluation Kit

logic-low. When their input logic is high, STH1 and STH2 output is connected to GHON; CKH1 and CKBH1 output is connected to GHC1; CKH2 and CKBH2 output is connected to GHC2. GHC1 and GHC2 are the output of the two high-voltage switching blocks.

The six switches within SW1 select logic levels on inputs ST1, ST2, CK1, CKB1, CK2, and CKB2 for testing purposes. Set each switch open when driving the inputs with external logic. Jumpers JU14–JU19 are used to select between capacitive loads on the outputs for testing purposes.

IN Power Supply (JU2)

The MAX17100 IN pin can be supplied directly from the VS pad or from an on-board linear regulator through configuration of jumper JU2. See Table 1 for jumper JU2 configuration.

Level-Shifter Logic-Level Inputs (JU6–JU11)

The MAX17100 level-shifter inputs can be supplied using the on-board logic or from an externally applied signal through configuration of jumpers JU6–JU11. Additionally, when using on-board logic, SW1 controls the logic levels based on its own settings. When SW1 is on, the logic input is high. When SW1 is off, the logic input is pulled low through a 100k Ω pulldown resistor. See Table 2 for jumper configuration.

Level-Shifter Output Loading (JU14–JU19)

The MAX17100 EV kit incorporates jumpers JU14–JU19 to provide loading options at the level-shifter outputs (STH1, STH2, CKH1, CKBH1, CKH2, and CKBH2). See Table 3 for jumper configuration.

Output-Voltage Selection

The MAX17100 EV kit's step-up switching-regulator output (VMAIN) is set to +14V by feedback resistors R56 and R57. To generate output voltages other than +14V, select different external voltage-divider resistors, R56 and R57. Note that changing the VMAIN voltage setting changes the VGOFF and VGHON charge-pump output voltages. Refer to the *Step-Up Regulator, Output-Voltage Selection* section in the MAX17100 IC data sheet for more information.

Table 1. Jumper JU2 Functions

SHUNT POSITION	IN PIN
1-2	Powered directly through VS input
2-3*	Powered through 3.3V LDO (U9)

*Default position.

Table 2. Jumper JU6–JU11 Functions

SHUNT POSITION	LEVEL-SHIFTER INPUT PINS
1-2	Supplied through external signal applied at the SCAN_IN pad
2-3*	Supplied on-board based on SW1 states

*Default position.

Table 3. Jumper JU14–JU19 Functions

SHUNT POSITION	LEVEL-SHIFTER OUTPUT PINS
1-2	Minimum loading
2-3*	Maximum loading

*Default position.

Detailed Description of Software

The MAX17100 device includes a calibrator used for adjusting an LCD's backplane voltage (VCOM) in TFT-LCD displays. The VCOM voltage is adjusted by controlling the amount of sink current drawn by the calibrator. This is accomplished by programming the desired setting into the device's 7-bit internal DAC. The software also facilitates reading of the device and programming of the device's internal nonvolatile memory. Refer to the MAX17100 IC data sheet for further details.

Loading 7-Bit DAC Setting

The DAC setting corresponds to a certain sink-current level, which in turn corresponds to a specific VCOM voltage. With the MAX17100 EV kit software, the device's 7-bit internal DAC is configured by entering an appropriate DAC setting into the **Load DAC** edit box. The DAC setting can be set from 0x00 (VCOM_{MAX}) to 0x7F (VCOM_{MIN}). The DAC setting is written to the device by pressing the **Load DAC** button (Figure 1).

Reading 7-Bit DAC

The MAX17100 7-bit DAC can be read by pressing the **Read DAC** button or by checking the **DAC polling** checkbox. When checked, the software continuously reads and displays the DAC's current setting.

Programming Nonvolatile Memory

The current DAC setting can be programmed into the device's internal nonvolatile memory by pressing the **Program** button. Each time the device is powered-on, the DAC is loaded with the setting stored in the device's nonvolatile memory. Programming is only possible when GON is greater than 16V and WR# is low.

MAX17100 Evaluation Kit

Evaluates: MAX17100

Simple SMBus Commands

There are two methods for communicating with the MAX17100, through the MAX17100 EV kit software main window (Figure 1), or through the interface window available by selecting the **Action | Interface Diagnostic Window** menu item from the menu bar. The Maxim command module interface window (Figure 2) includes a **2-wire interface** tab that allows for execu-

tion of the **SMBusSendByte()**, **SMBusReceiveByte()**, and **SMBusQuick()** commands. See Table 4 for details regarding SMBus commands.

The **Command byte** combo box accepts numeric data in binary, decimal, or hexadecimal. Hexadecimal numbers should be prefixed by \$ or 0x. Binary numbers must be exactly eight digits. See Figure 2 for an illustration of this tool.

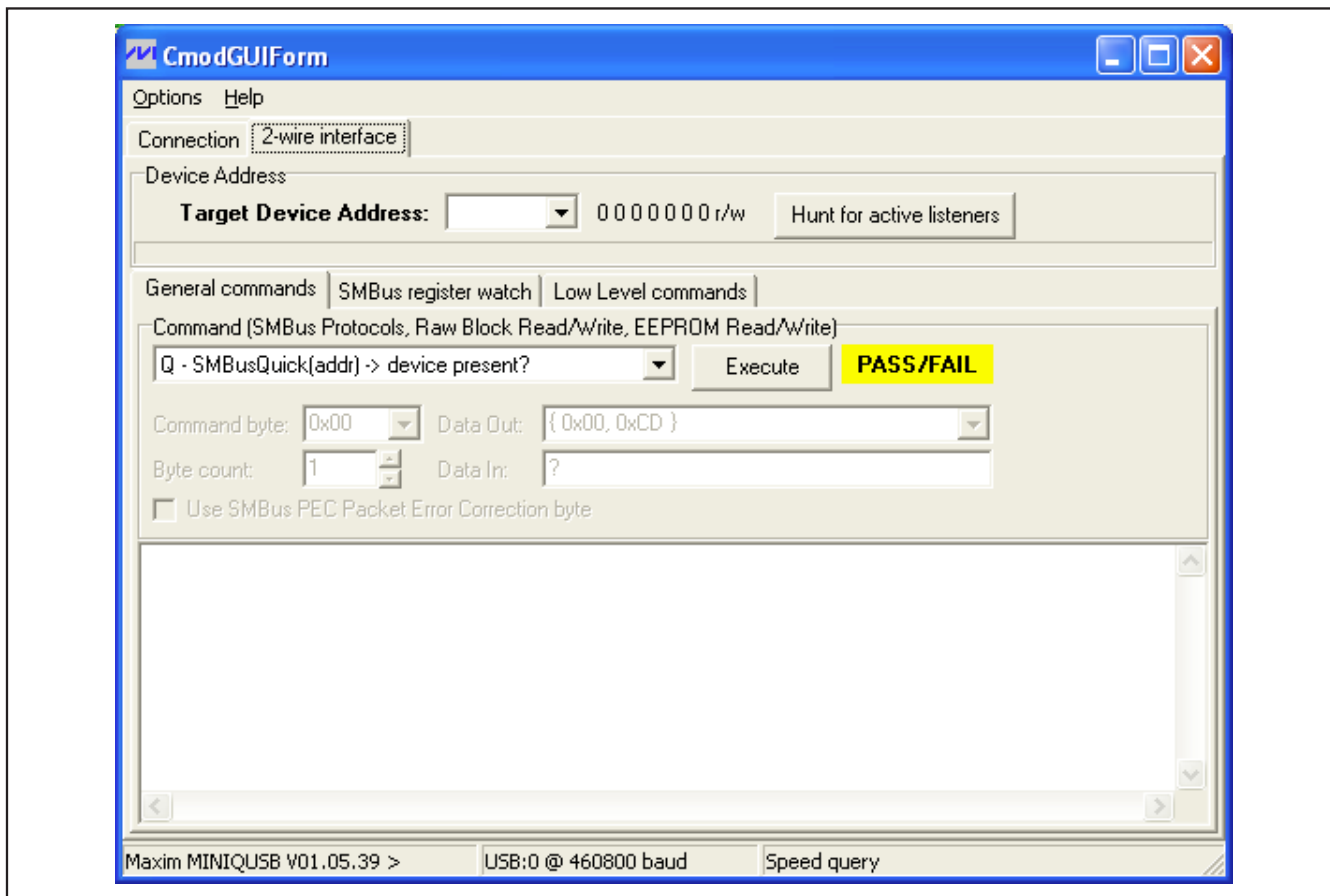

Figure 2. Command Module Interface Window

Table 4. SMBus Commands

CONTROL	SMBus COMMAND	FORMAT
Load DAC	SMBusSendByte	Input the desired 7-bit DAC setting into the Command byte combo box. The 7-bit DAC value should be stored in the upper 7 bits (b7–b1) of the byte, with the LSB = 1.
Read DAC	SMBusReceiveByte	Receives 8 bits from the device. The upper 7 bits correspond to the current DAC setting and the LSB = 0.
Device search	SMBusQuick	Search for device address shown in the Target Device Address combo box. The MAX17100 device address can be 50, 52, 54, or 56.

MAX17100 Evaluation Kit

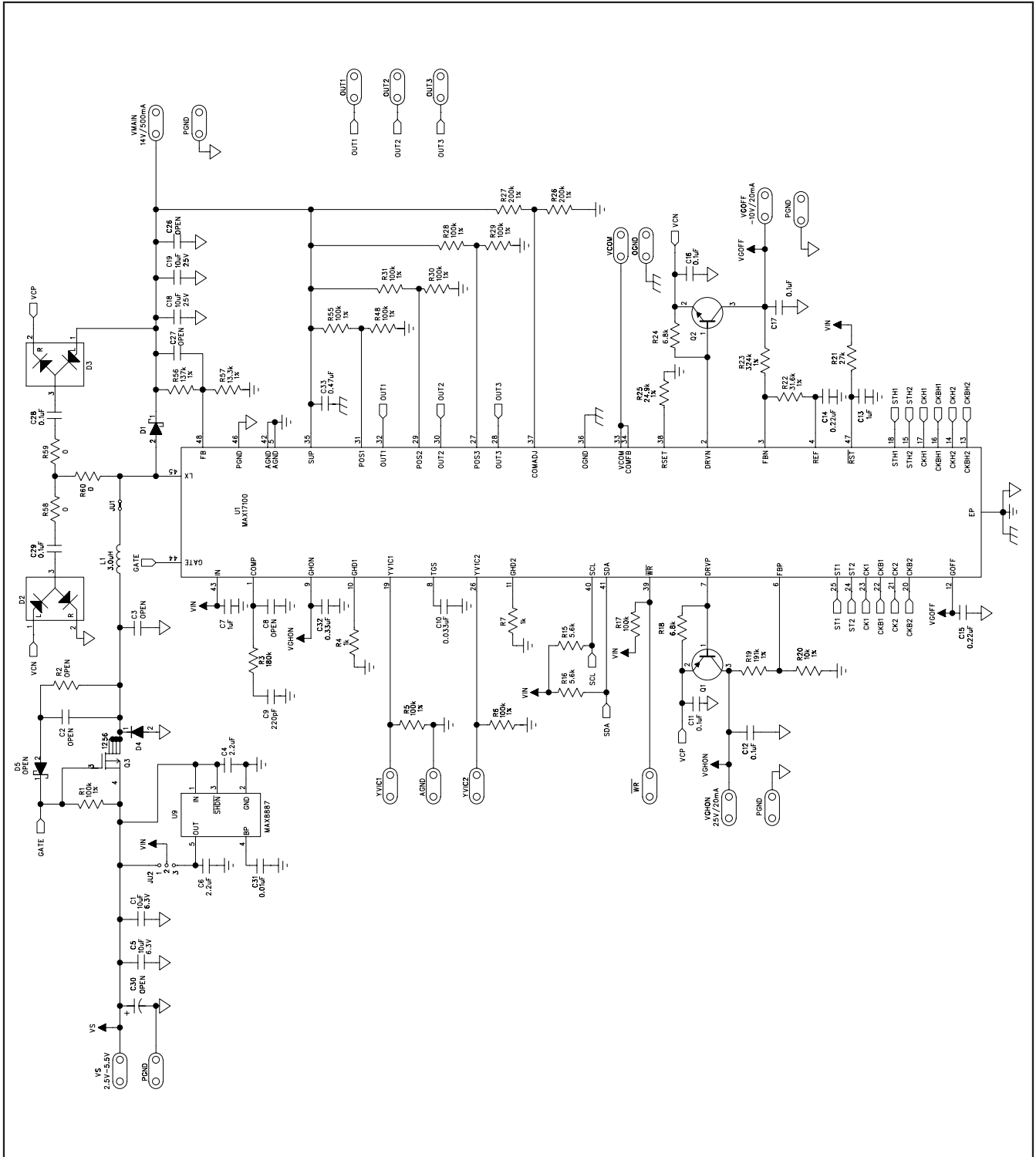

Figure 3a. MAX17100 EV Kit Schematic (Sheet 1 of 3)

MAX17100 Evaluation Kit

Evaluates: MAX17100

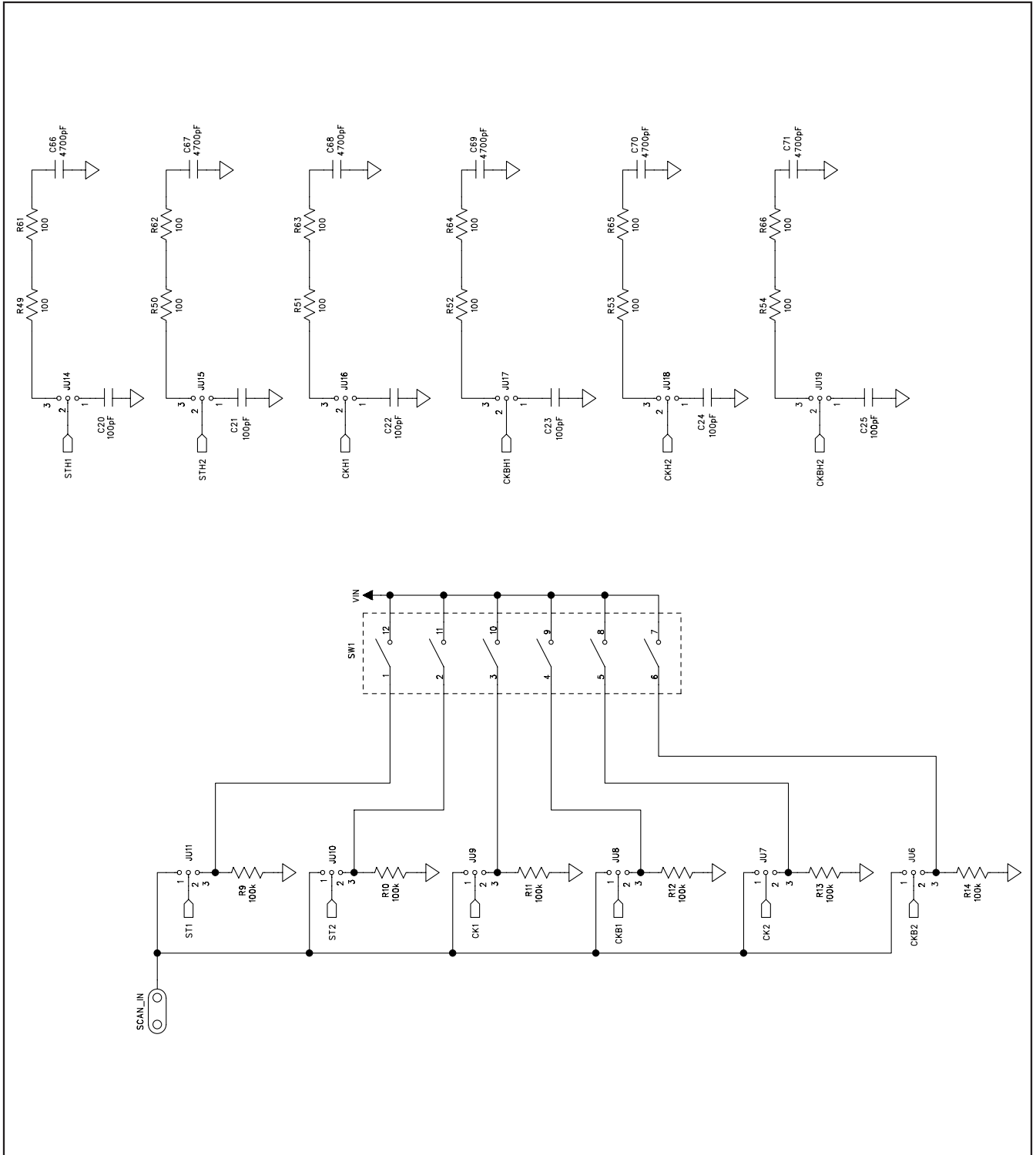

Figure 3b. MAX17100 EV Kit Schematic (Sheet 2 of 3)

MAX17100 Evaluation Kit

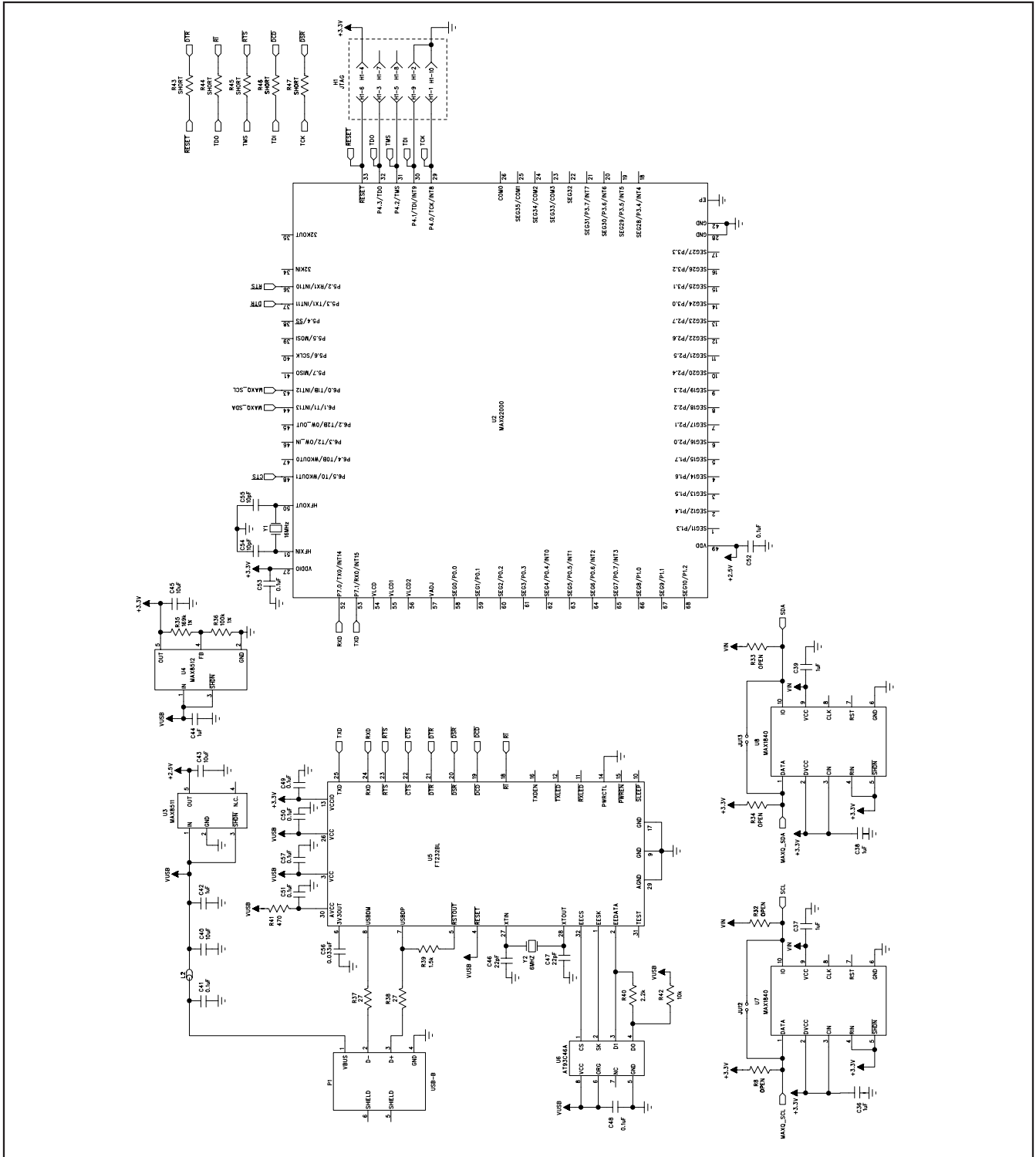

Figure 3c. MAX17100 EV Kit Schematic (Sheet 3 of 3)

MAX17100 Evaluation Kit

Evaluates: MAX17100

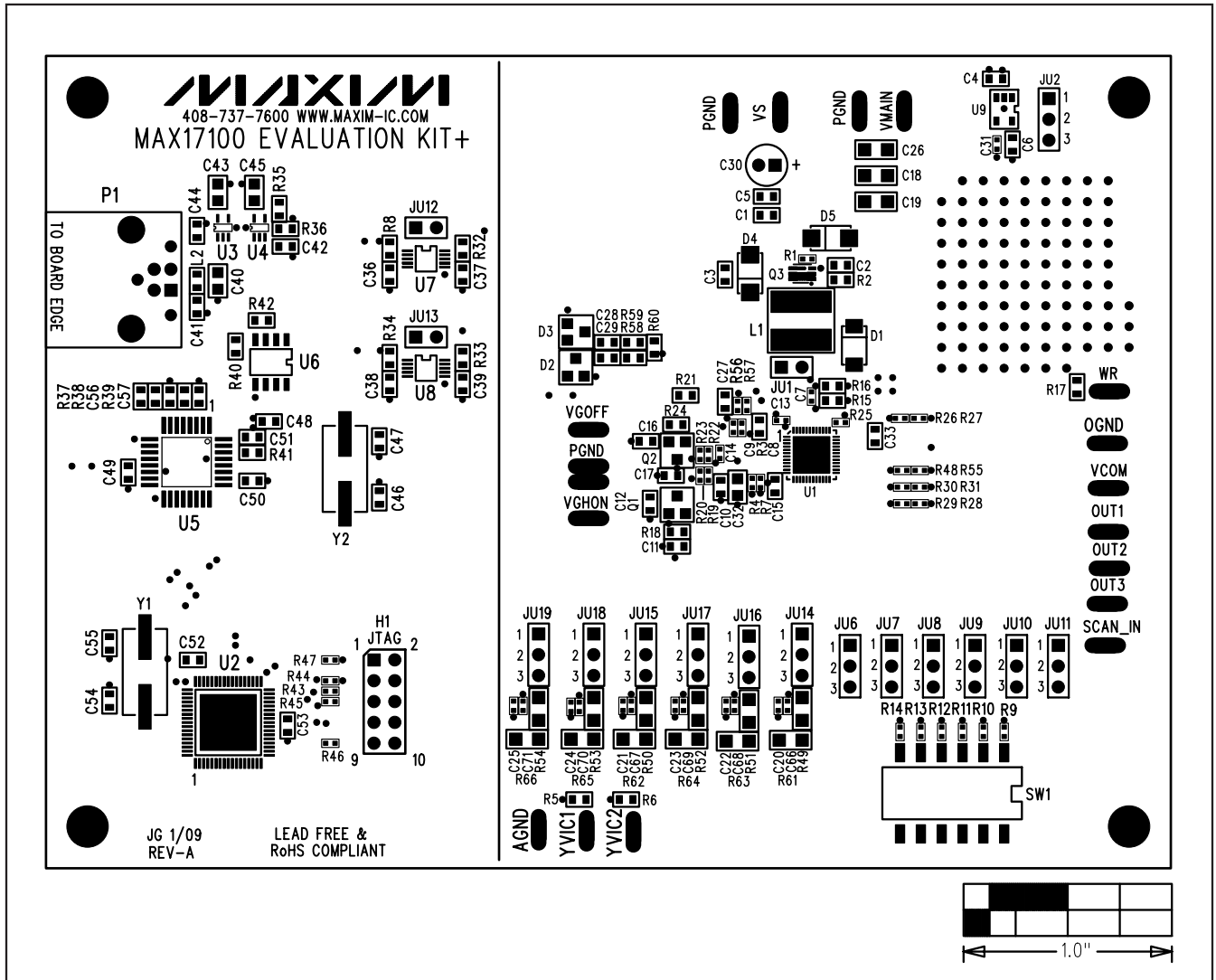

Figure 4. MAX17100 EV Kit Component Placement Guide—Component Side

MAX17100 Evaluation Kit

Evaluates: MAX17100

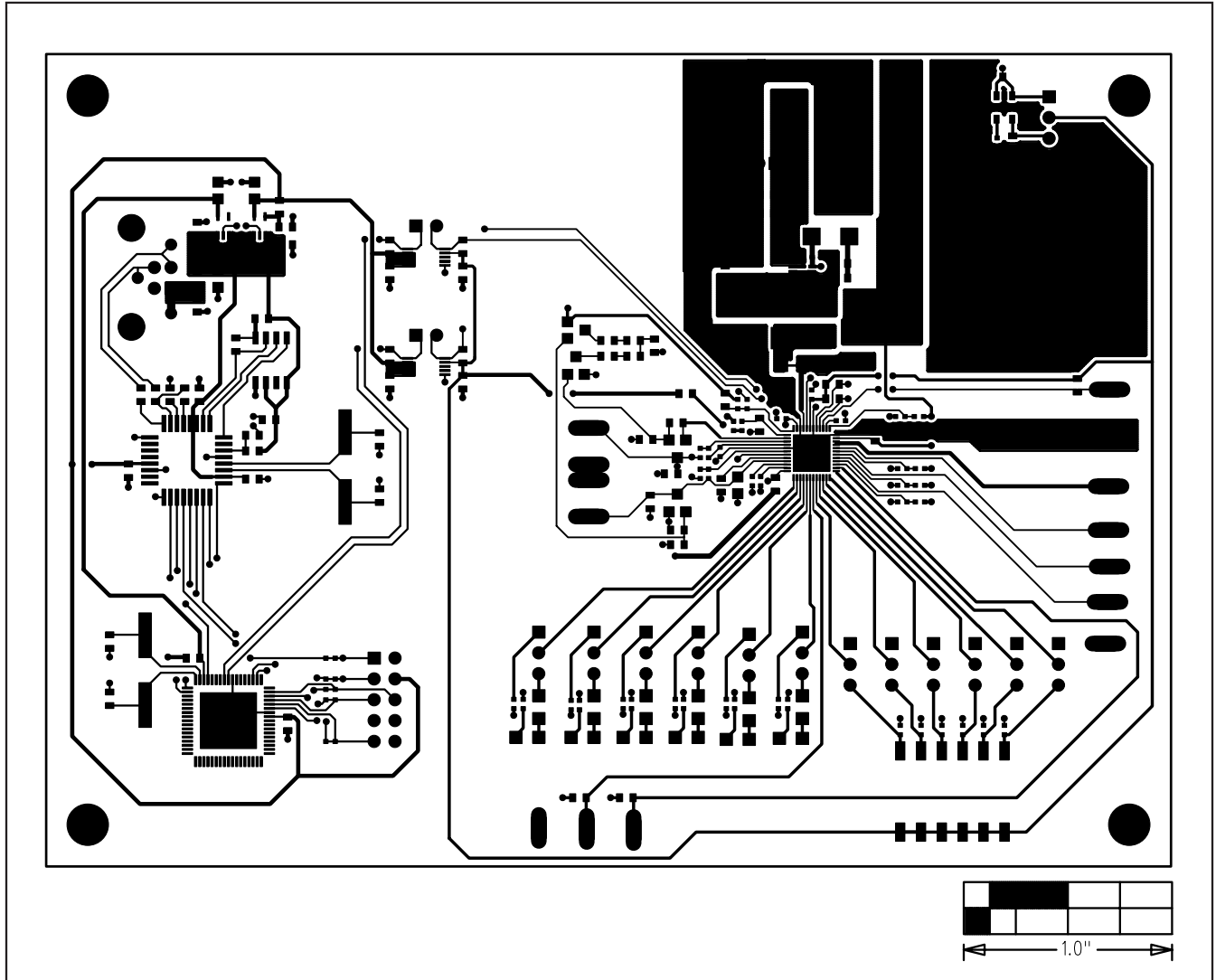

Figure 5. MAX17100 EV Kit PCB Layout—Component Side

MAX17100 Evaluation Kit

Evaluates: MAX17100

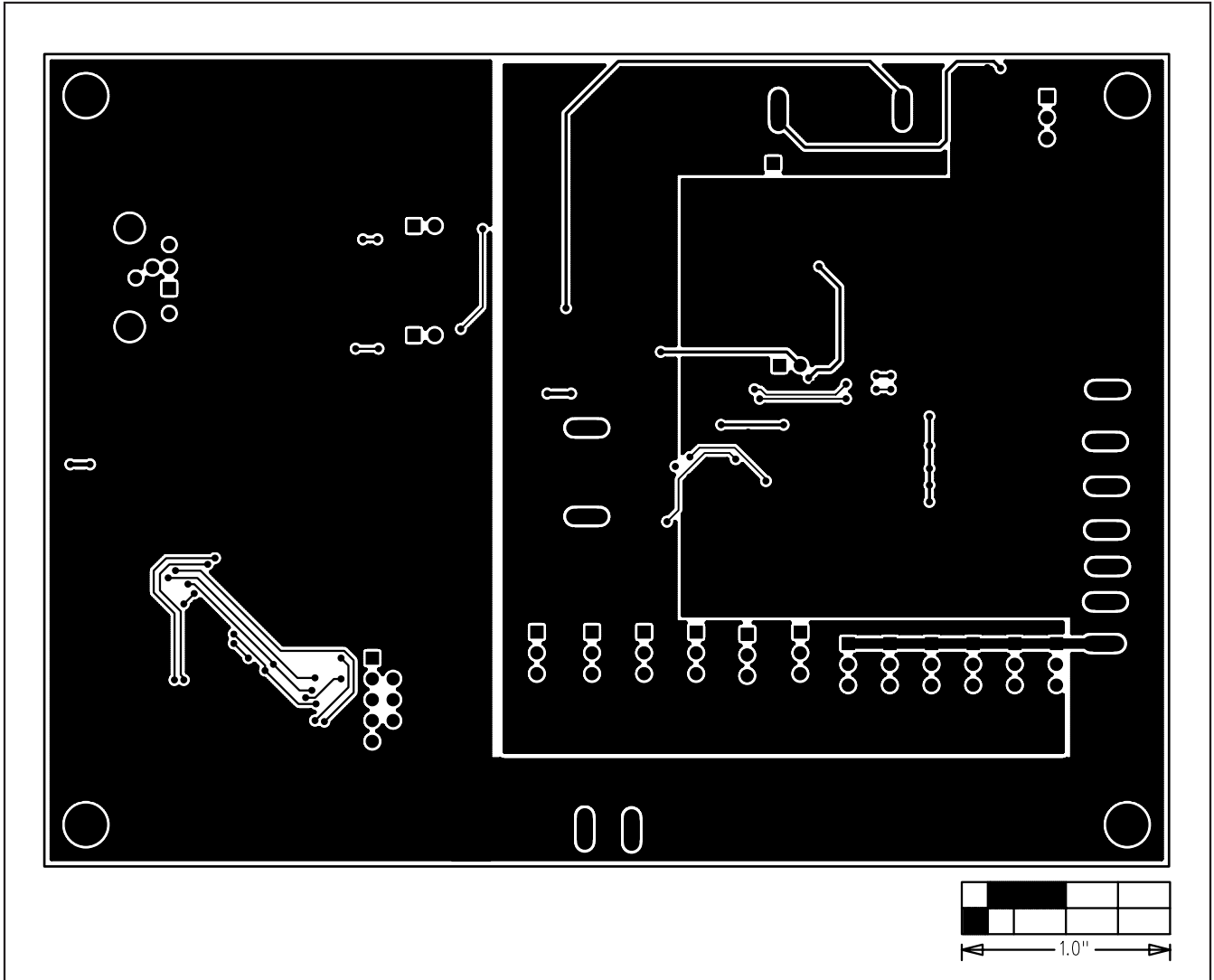

Figure 6. MAX17100 EV Kit PCB Layout—Solder Side

Maxim cannot assume responsibility for use of any circuitry other than circuitry entirely embodied in a Maxim product. No circuit patent licenses are implied. Maxim reserves the right to change the circuitry and specifications without notice at any time.

Maxim Integrated Products, 120 San Gabriel Drive, Sunnyvale, CA 94086 408-737-7600 _____ 13