

PART NUMBER	REV	TERMINATOR	FEED TYPE	DESCRIPTION
1528543-1	A	LEADMAKER	MECH POST FEED	CUTS CARRIER
1528543-2	A	BENCH	MECH PRE FEED	CUTS CARRIER
1528543-6	A	LEADMAKER	MECH POST FEED	CONTINUOUS CARRIER
7-1528543-1	A	LEADMAKER	MECH POST FEED	-1 AND SPARE PARTS
7-1528543-2	A	BENCH	MECH PRE FEED	-2 AND SPARE PARTS
7-1528543-6	A	LEADMAKER	MECH POST FEED	-6 AND SPARE PARTS
7-1528543-7	A	-	-	SPARE PARTS KIT

CRIMP DATA		GHW TERMINAL	GHW CRIMP SPEC
TERMINAL NAME: DFK 40 TIMER TYPE CTC 4.8 X 0.8 - 2.5			
CRIMP	SIZE	TYPE	RANGE
WIRE	2.79 [.110 IN]	F	1.50-2.50mm ²
INSUL	3.94 [.155 IN]	OV	2.40-3.10 [.094-.122 IN]
WIRE STRIP LENGTH 5.50 mm [.217 in]		APPL INSTRUCTIONS 408-8322 & 408-8490	
TERMINAL APPL SPEC		LEAR DATA SHT 26965	FEED 18.50 [.728 IN]
TERMINALS APPLIED			
TYCO PN	MANUF PN		
1572727-1	26965-306-179		
WIRE SIZE		CRIMP HEIGHT	REF SETTING
2.50mm sq		1.90 ±0.05 [.075 ±.002 IN]	B 7
1.50mm sq		1.70 ±0.05 [.067 ±.002 IN]	D 0

- RECOMMENDED SPARE PARTS
- GREASE RAM, CAM, CAM FOLLOWER AND FEED ROD LIGHTLY
- LUBRICATE DAILY PER THE APPLICATOR INSTRUCTION SHEET SUPPLIED WITH THE APPLICATOR
- ALL CRIMP DATA SUPPLIED BY TERMINAL MANUFACTURER.
- THIS APPLICATOR HAS BEEN DESIGNED TO APPLY WIRES WITH THIN WALL (FLR) INSULATION. THE INSULATION CRIMP & APPLICABLE INSULATION RANGE MAY NOT CONFORM TO PARAMETERS LISTED IN THE APPLICATION SPECIFICATION.

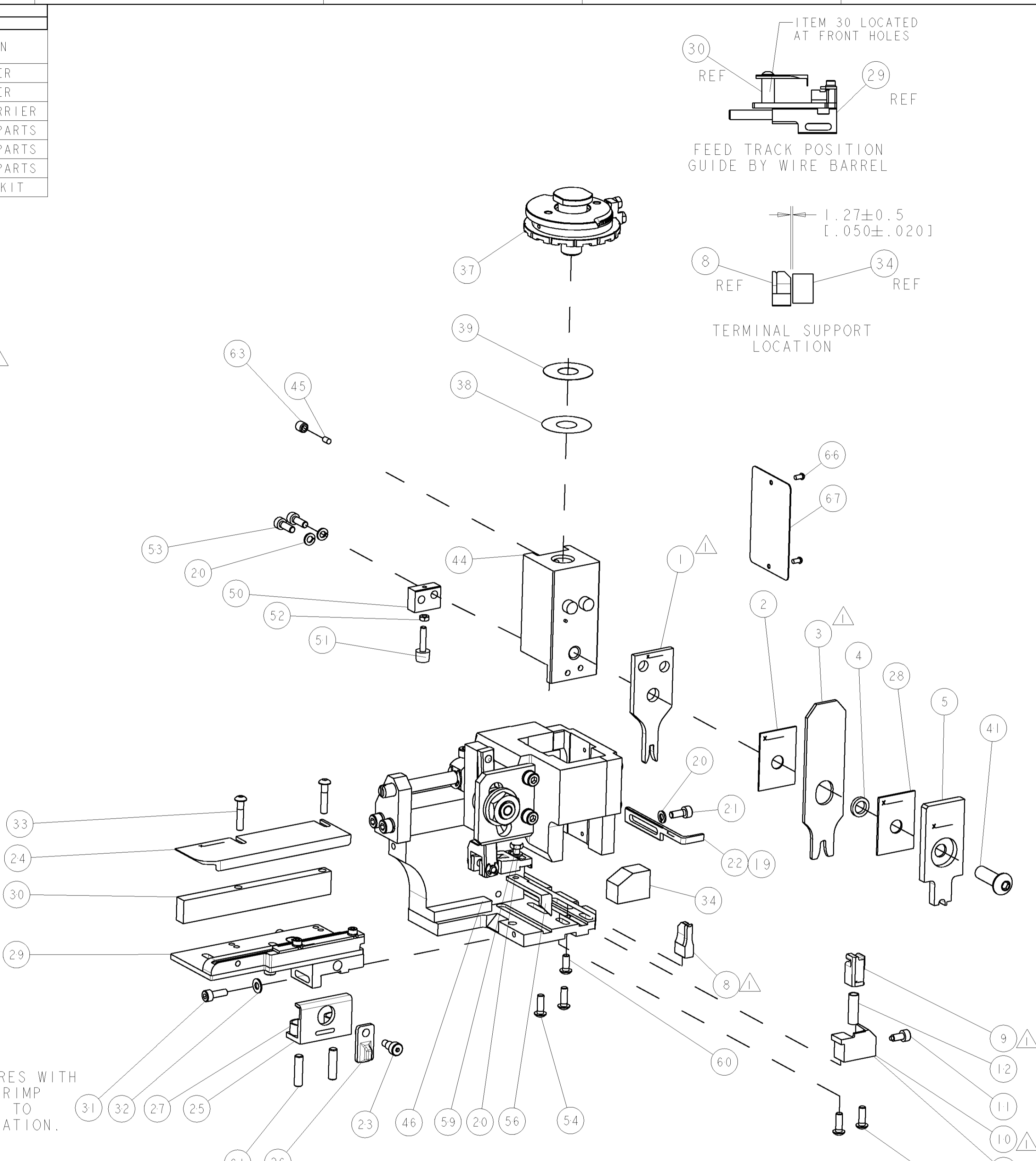

*** WARNING**
ON INSTALLATION, SET WIRE DISC TO LARGEST WIRE SIZE SETTING. USE OF SETTINGS BELOW MIN. REQUIRED CRIMP HEIGHT SETTING WILL CAUSE DAMAGE TO CRIMP TOOLING.

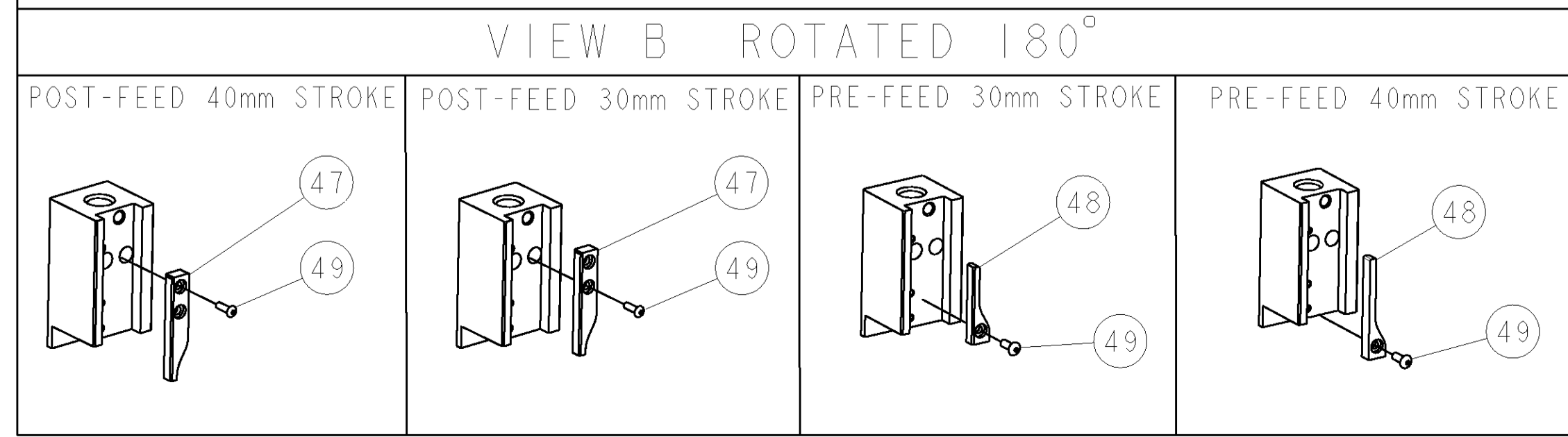

-77	-76	-72	-71	-6	-2	-1	PART NO	DESCRIPTION	ITEM NO
-	-	-	-	-	-	-	-	-	84
-	-	-	-	-	-	-	-	-	83
-	-	-	-	-	-	-	-	-	82
-	-	-	-	-	-	-	-	-	81
-	-	-	-	-	-	-	-	-	80
-	-	-	-	-	-	-	-	-	79
-	-	-	-	-	-	-	-	-	78
-	-	-	-	-	-	-	-	-	77
-	-	-	-	-	-	-	-	-	76
-	-	-	-	-	-	-	-	-	75
-	-	-	-	-	-	-	-	-	74

SET UP GAGE
458637-3

LOC		DIST		REVISONS			
A	66	P	LTR	DESCRIPTION	DATE	BY	APPD
A	66	A		SEE ECO-05-005210	12JUL2005	LJL	FB

-	-	-	-	-	-	-	-	-	73
-	-	-	-	-	-	-	-	-	72
-	-	-	-	-	-	-	-	-	71
-	-	-	-	-	-	-	-	-	70
-	-	-	-	-	-	-	-	-	69
-	-	-	-	-	-	-	-	-	68
-	-	-	-	-	-	-	-	-	67
-	-	-	-	-	-	-	-	-	66
-	-	-	-	-	-	-	-	-	65
-	-	-	-	-	-	-	-	-	64
-	-	-	-	-	-	-	-	-	63
-	-	-	-	-	-	-	-	-	62
-	-	-	-	-	-	-	-	-	61
-	-	-	-	-	-	-	-	-	60
-	-	-	-	-	-	-	-	-	59
-	-	-	-	-	-	-	-	-	58
-	-	-	-	-	-	-	-	-	57
-	-	-	-	-	-	-	-	-	56
-	-	-	-	-	-	-	-	-	55
-	-	-	-	-	-	-	-	-	54
-	-	-	-	-	-	-	-	-	53
-	-	-	-	-	-	-	-	-	52
-	-	-	-	-	-	-	-	-	51
-	-	-	-	-	-	-	-	-	50
-	-	-	-	-	-	-	-	-	49
-	-	-	-	-	-	-	-	-	48
-	-	-	-	-	-	-	-	-	47
-	-	-	-	-	-	-	-	-	46
-	-	-	-	-	-	-	-	-	45
-	-	-	-	-	-	-	-	-	44
-	-	-	-	-	-	-	-	-	43
-	-	-	-	-	-	-	-	-	42
-	-	-	-	-	-	-	-	-	41
-	-	-	-	-	-	-	-	-	40
-	-	-	-	-	-	-	-	-	39
-	-	-	-	-	-	-	-	-	38
-	-	-	-	-	-	-	-	-	37
-	-	-	-	-	-	-	-	-	36
-	-	-	-	-	-	-	-	-	35
-	-	-	-	-	-	-	-	-	34
-	-	-	-	-	-	-	-	-	33
-	-	-	-	-	-	-	-	-	32
-	-	-	-	-	-	-	-	-	31
-	-	-	-	-	-	-	-	-	30
-	-	-	-	-	-	-	-	-	29
-	-	-	-	-	-	-	-	-	28
-	-	-	-	-	-	-	-	-	27
-	-	-	-	-	-	-	-	-	26
-	-	-	-	-	-	-	-	-	25
-	-	-	-	-	-	-	-	-	24
-	-	-	-	-	-	-	-	-	23
-	-	-	-	-	-	-	-	-	22
-	-	-	-	-	-	-	-	-	21
-	-	-	-	-	-	-	-	-	20
-	-	-	-	-	-	-	-	-	19
-	-	-	-	-	-	-	-	-	18
-	-	-	-	-	-	-	-	-	17
-	-	-	-	-	-	-	-	-	16
-	-	-	-	-	-	-	-	-	15
-	-	-	-	-	-	-	-	-	14
-	-	-	-	-	-	-	-	-	13
-	-	-	-	-	-	-	-	-	12
-	-	-	-	-	-	-	-	-	11
-	-	-	-	-	-	-	-	-	10
-	-	-	-	-	-	-	-	-	9
-	-	-	-	-	-	-	-	-	8
-	-	-	-	-	-	-	-	-	7
-	-	-	-	-	-	-	-	-	6
-	-	-	-	-	-	-	-	-	5
-	-	-	-	-	-	-	-	-	4
-	-	-	-	-	-	-	-	-	3
-	-	-	-	-	-	-	-	-	2
-	-	-	-	-	-	-	-	-	1

ITEM NO	PART NO	DESCRIPTION
84		
83		
82		
81		
80		
79		
78		
77		
76		
75		
74		

LOC	DIST	REV	DATE	BY	APPD
A	66		12-Jul-05	LJL	FB

DIMENSIONS:	TOLERANCES UNLESS OTHERWISE SPECIFIED:
mm [IN]	0 PLC ±
	1 PLC ±
	2 PLC ±
	3 PLC ±
	4 PLC ±
	ANGLES ±

MATERIAL	FINISH	WEIGHT	CUSTOMER DRAWING
-	-	-	-

SCALE	SHEET	OF	REV
3:5	1	1	A