

SOT-25

Pin Definition:

1. Input +
2. Ground
3. Input -
4. Output
5. Vcc

General Description

The TS321 brings performance and economy to low power systems. With high unity gain frequency and a guaranteed 0.4V/uS slew rate, the quiescent current is only 430uA/amplifier (5V). The input common mode range includes ground and therefore the device is able to operate in single supply applications as well as in dual supply applications. It is also capable of comfortably driving large capacitive loads.

The TS321 is available in the SOT-25 package. Overall the TS321 is a low power, wide supply range performance OP Amp that can be designed into a wide range of applications at an economical price without sacrificing valuable board space.

Features

- Short circuit protected outputs
- True differential input stage
- Wide supply voltage range +3V to 32V
- Low input bias currents
- Internally compensated
- Common mode range extends to negative supply
- Single Version of TS324

Applications

- Chargers
- Power Supplies
- Industrial: Controls, Instruments
- Desktops
- Communications Infrastructure

Block Diagram

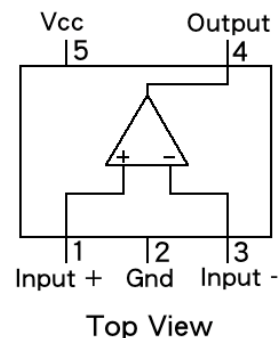

Ordering Information

Part No.	Package	Packing
TS321CX5 RFG	SOT-25	3,000pcs / 7" Reel

Absolute Maximum Rating

Parameter	Symbol	Limit	Unit
Supply Voltage	V _{CC}	+32	V
Input Voltage	V _{IN}	-0.3 to +32	V
Input Current (V _{IN} < -0.3V)	V _I	50	mA
Output Short Circuit Duration	t _{SC}	Continuous	
Operating Temperature Range	T _{OPR}	-40 ~ +85	°C
Storage Temperature Range	T _{STG}	-65 ~ +150	°C
Mounting Temperature (Soldering @ 260°C)		10	S
Thermal Resistance Junction to Ambient	R _{θJA}	265	°C/W

Electrical Characteristics Unless otherwise specified, all limits guarantee for at $T_A=25^\circ\text{C}$, $V_+=5\text{V}$, $V_-=5\text{V}$, $V_O=1.4\text{V}$. **Boldface** limits apply at temperature extremes.

Symbol	Parameter	Conditions	Min	Typ	Max	Units	
V_{OS}	Input Offset Voltage	(Note 1)	-- --	2 --	7 9	mV	
I_{OS}	Input Offset Current		-- --	5 --	50 150	nA	
I_B	Input Bias Current (Note 8)		-- --	45 --	250 500	nA	
V_{CM}	Input Common-Mode Voltage Range	$V_+ = 30\text{V}$ (Note 9) For $CMRR > = 50\text{dB}$	0 --	-- --	$V_+ - 1.5$ $V_+ - 2$	V	
A_V	Large Signal Voltage Gain	$(V_+ = 15\text{V}, R_L = 2\text{k}\Omega$ $V_O = 1.4\text{V to } 11.4\text{V})$	25 15	100 --	-- --	V/mV	
PSRR	Power Supply Rejection Ratio	$R_S \leq 10\text{k}\Omega, V_+ \leq 5\text{V to } 30\text{V}$	65	100	--	dB	
CMRR	Common Mode Rejection Ratio	$R_S \leq 10\text{k}\Omega$	65	85	--	dB	
V_O	Output Swing	VOH	$V_+ = 30\text{V}, R_L = 2\text{k}\Omega$	26	--	--	V
			$V_+ = 30\text{V}, R_L = 10\text{k}\Omega$	27	28	--	
		VOL	$V_+ = 5\text{V}, R_L = 10\text{k}\Omega$	--	5	20	mV
I_S	Supply Current, No Load	$V_+ = 5\text{V}$	-- --	0.43 0.7	1.15 1.2	mA	
		$V_+ = 30\text{V}$	-- --	0.66 1.5	2.85 3		
I_{SOURCE}	Output Current Sourcing	$V_{ID} = +1\text{V}, V_+ = 15\text{V},$ $V_O = 2\text{V}$	20 10	40 20	-- --	mA	
I_{SINK}	Output Current Sinking	$V_{ID} = -1\text{V}$ $V_+ = 15\text{V}, V_O = 2\text{V}$	10 5	20 8	-- --	mA	
		$V_{ID} = -1\text{V}$ $V_+ = 15\text{V}, V_O = 0.2\text{V}$	-- 12	-- 100	-- --	μA	
I_O	Output Short Circuit to Ground	$V_+ = 15\text{V}$	--	40	85	mA	
SR	Slew Rate	$V_+ = 15\text{V}, R_L = 2\text{k}\Omega,$ $V_{IN} = 0.5 \text{ to } 3\text{V}$ $C_L = 100\text{pF}, \text{Unity Gain}$	--	0.4	--	V/ μs	
GBW	Gain Bandwidth Product	$V_+ = 30\text{V}, f = 100\text{kHz},$ $V_{IN} = 10\text{mV}, R_L = 2\text{k}\Omega,$ $C_L = 100\text{pF}$	--	1	--	MHz	
THD	Total Harmonic Distortion	$f = 1\text{kHz}, A_V = 20\text{dB}$ $R_L = 2\text{k}\Omega, V_O = 2V_{PP}$ $C_L = 100\text{pF}, V_+ = 30\text{V}$	--	0.015	--	%	
e_n	Equivalent Input Noise Voltage	$f = 1\text{kHz}, R_S = 100\Omega$ $V_+ = 30\text{V}$	--	40	--	nV	

Note:

- $V_O \approx 1.4\text{V}$, $R_S=0\Omega$ with V_+ from 5V to 30V; and over the full input common-mode range($0\text{V} \sim V_+ - 1.5\text{V}$) at 25°C
- short circuits from the output V^+ can cause excessive heating and eventual destruction. When considering short circuits to ground the maximum output current is approximately 40mA independent of the magnitude of V^+ values of supply voltage in excess of +15v, continuous short circuit can exceed the power dissipation ratings and cause eventual destruction.

Application Hints

The TS321 OP amp can operate with a single or dual power supply voltage has true-differential inputs, and remain in the linear mode with an input common-mode voltage of $0 V_{DC}$. This amplifier operates over a wide range of power supply voltages, with little change in performance characteristics. At $25^{\circ}C$ amplifier operation is possible down to a minimum supply voltage of 3V.

Large differential input voltage can be easily accommodates and, as input differential voltage protection diodes are not needed, no large input currents result from large differential input voltage. The differential input voltage may be larger than V^+ without damaging the device. Protection should be provided to prevent the input voltage from going negative more than $-0.3 V_{DC}$ (at $25^{\circ}C$).

An input clamp diode with a resistor to the IC input terminal can be used.

To reduce the power supply drain, the amplifier has a class A output stage for small signal levels which converts to class B in a large signal mode. This allows the amplifiers to both source and sink large output currents. Therefore both NPN and PNP external current boots transistor can be used to extend the power capability of the basic amplifiers. The output voltage needs to raise approximately 1 diode drop above ground to bias the on-chip vertical PNP transistor for output current sinking applications.

For AC applications, where the load is capacitively coupled to the output of the amplifier, a resistor should be used, from the output of the amplifier to ground to increase the class A bias current and to reduce distortion. Capacitive loads which are applied directly to the output of the amplifier reduce the loop stability margin. Values of 50pF can be accommodated using the worst-case non-inverting unity gain connection. Large closed loop gains or resistive isolation should be used if large load capacitance must be driven by the amplifier

The bias network of the TS312 establishes a supply current which is independent of the magnitude of the magnitude of the power supply voltage over the range of from $3V_{DC}$ to $3V_{DC}$.

Output short circuits either to ground or to the positive power supply should be of short time duration. Units can be destroyed, not as a result of the short circuit current causing metal fusing, but rather due to the large increase in IC chip dissipation which cause eventual failure due to excessive junction temperatures. The large value of output source current which is available at $25^{\circ}C$, provides a large output current capability at elevated temperature than a standard IC op amp.

The circuits presented in the section on typical applications emphasize operation on only a single power supply voltage. If complementary power supplies are available, all of the standard op amp circuits can be used. In general, introducing a pseudo-ground (a bias voltage reference of $V^+/2$) will allow operation above and below this value in single power supply systems. Many application circuits are shown which take advantage of the wide input common-mode voltage range which includes ground. In most cases, input biasing is not required and input voltage which range to ground can easily be accommodated.

Typical Applications

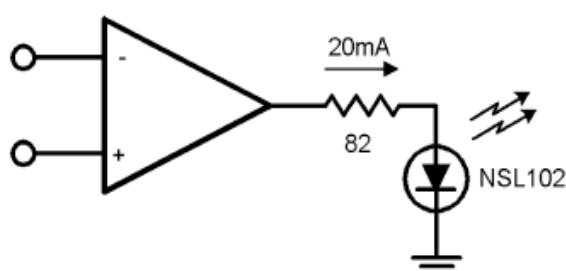

Figure 1. LED Driver

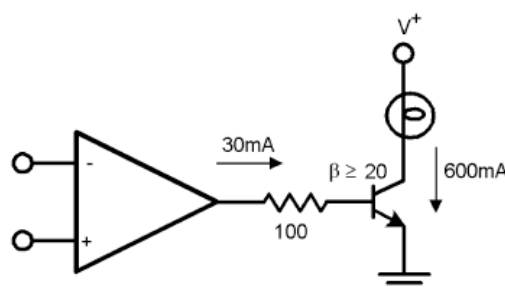
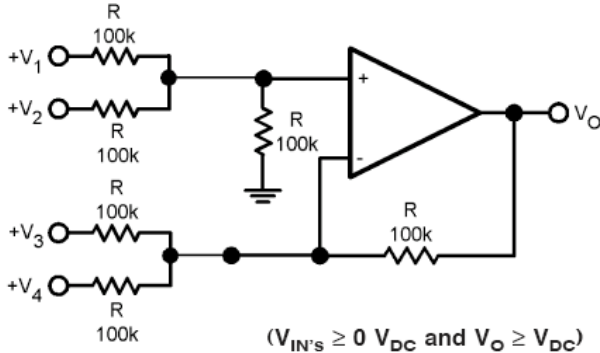

Figure 2. Lamp Driver

Typical Applications (Continues)



Where: $V_O = V_1 + V_2 - V_3 - V_4$, $(V_1 + V_2) \geq (V_3 + V_4)$ to keep $V_O > 0 \text{ V}_{DC}$

Figure 3. DC Summing Amplifier

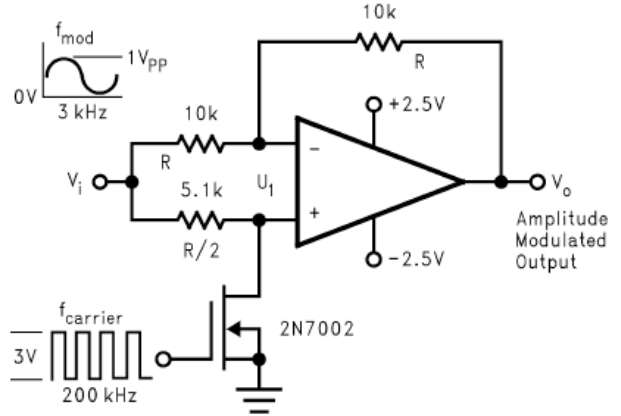

Figure 4. Amplitude Modulator Circuit

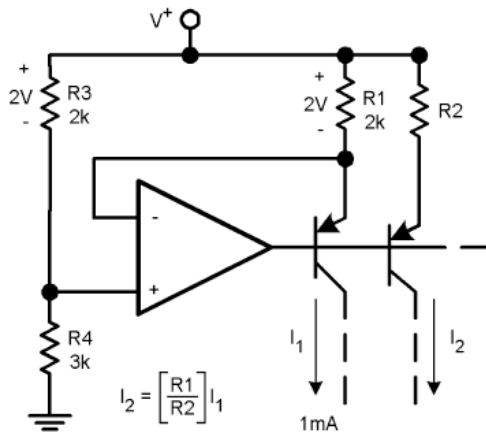

Figure 5. Fixed Current Sources

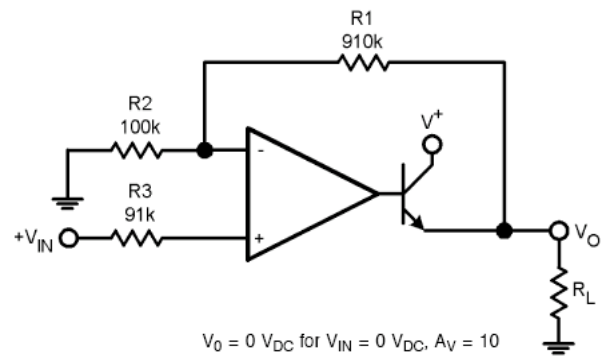
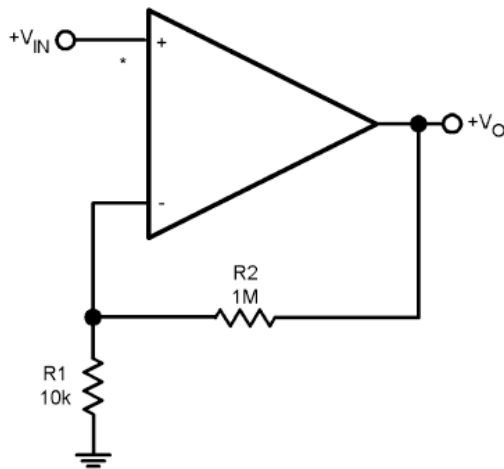

Figure 6. Power Amplifier



* R NOT NEEDED DUE TO TEMPERATURE INDEPENDENT I_{IN}

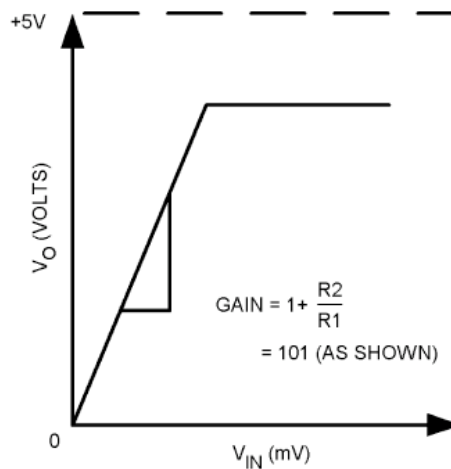
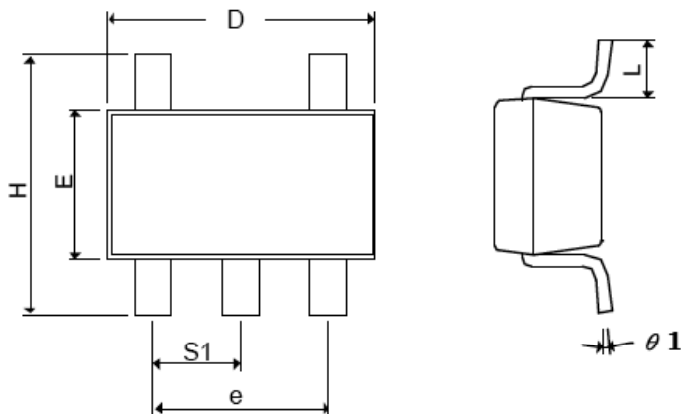

Figure 7. Non-Inverting DC Gain (0V Input = 0V Output)

SOT-25 Mechanical Drawing



DIM	MILLIMETERS		INCHES	
	MIN	MAX	MIN	MAX.
A+A1	0.09	1.25	0.0354	0.0492
B	0.30	0.50	0.0118	0.0197
C	0.09	0.25	0.0035	0.0098
D	2.70	3.10	0.1063	0.1220
E	1.40	1.80	0.0551	0.0709
E	1.90 BSC		0.0748 BSC	
H	2.40	3.00	0.09449	0.1181
L	0.35 BSC		0.0138 BSC	
$\theta 1$	0°	10°	0°	10°
S1	0.95 BSC		0.0374 BSC	

Front View

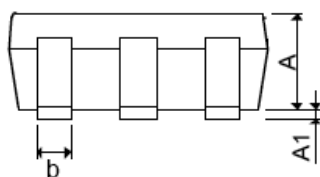

Marking Diagram

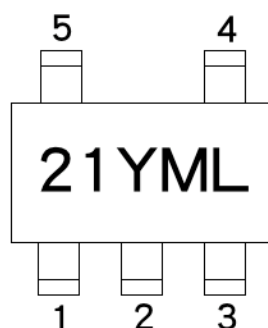

21 = Product Code for TS321CX5

Y = Year Code

M = Month Code for Halogen Free Product

O =Jan **P** =Feb **Q** =Mar **R** =Apr

S =May **T** =Jun **U** =Jul **V** =Aug

W =Sep **X** =Oct **Y** =Nov **Z** =Dec

L = Lot Code (1~9, A~Z)

Notice

Specifications of the products displayed herein are subject to change without notice. TSC or anyone on its behalf, assumes no responsibility or liability for any errors or inaccuracies.

Information contained herein is intended to provide a product description only. No license, express or implied, to any intellectual property rights is granted by this document. Except as provided in TSC's terms and conditions of sale for such products, TSC assumes no liability whatsoever, and disclaims any express or implied warranty, relating to sale and/or use of TSC products including liability or warranties relating to fitness for a particular purpose, merchantability, or infringement of any patent, copyright, or other intellectual property right.

The products shown herein are not designed for use in medical, life-saving, or life-sustaining applications. Customers using or selling these products for use in such applications do so at their own risk and agree to fully indemnify TSC for any damages resulting from such improper use or sale.