

COUNT	DESCRIPTION OF REVISIONS	BY	CHKD	DATE	COUNT	DESCRIPTION OF REVISIONS	BY	CHKD	DATE

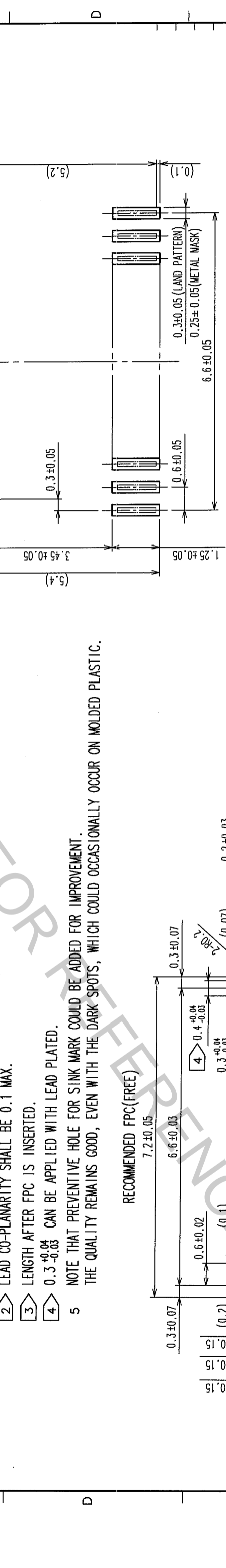
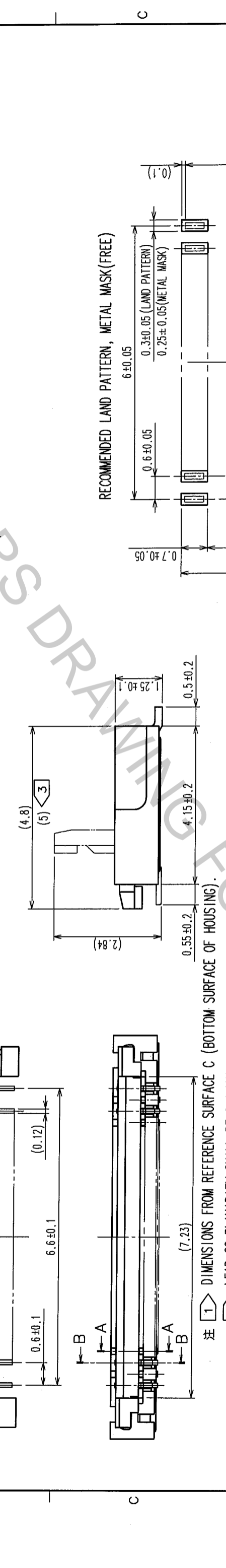
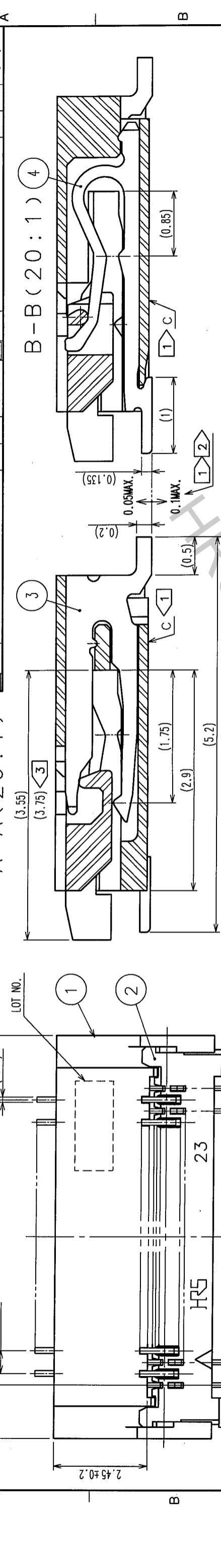

NO.	MATERIAL	FINISH, REMARKS	NO.	MATERIAL	FINISH, REMARKS
3	PHOSPHOR BRONZE	GOLD FLASH OVER NICKEL 1μm MIN.			
2	LCP	BLACK	UL94V-0		
1	LCP	BEIGE	UL94V-0	4	PHOSPHOR BRONZE
					GOLD FLASH OVER NICKEL 1μm MIN.

CODE NO. (OLD)	DRAWN	DESIGNED	CHECKED	APPROVED	RELEASED
	T. SHIBUYA	T. SHIBUYA		<i>A. Yamamoto</i>	
	04.11.24	04.11.24		04.11.29	

DRAWING NO.	PART NO.
EDC3-153988-02	FH23-23S-0.3SHW(05)

SCALE	UNITS
10 : 1	mm

RECOMMENDED LAND PATTERN, METAL MASK(FREE)

RECOMMENDED FPC(FREE)

RECOMMENDED STIFFENER MATERIAL: POLYIMIDE, HEAT CURED ADHESIVE.

- 注 1 DIMENSIONS FROM REFERENCE SURFACE C (BOTTOM SURFACE OF HOUSING).
- 2 LEAD CO-PLANARITY SHALL BE 0.1 MAX.
- 3 LENGTH AFTER FPC IS INSERTED.
- 4 0.3<sup>+0.04</sup><sub>-0.03</sub> CAN BE APPLIED WITH LEAD PLATED.
- 5 NOTE THAT PREVENTIVE HOLE FOR SINK MARK COULD BE ADDED FOR IMPROVEMENT. THE QUALITY REMAINS GOOD, EVEN WITH THE DARK SPOTS, WHICH COULD OCCASIONALLY OCCUR ON MOLDED PLASTIC.

COUNT	DESCRIPTION OF REVISIONS	BY	CHKD	DATE	COUNT	DESCRIPTION OF REVISIONS	BY	CHKD	DATE
△					△				
△					△				
△					△				

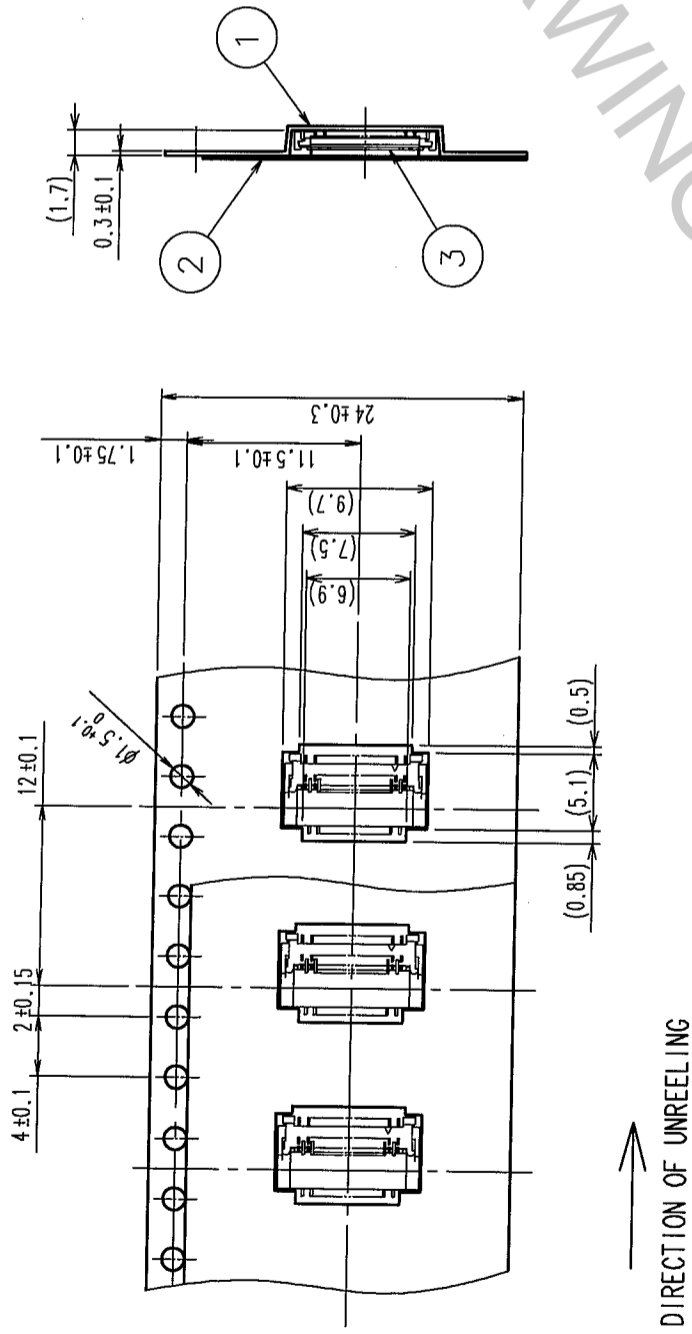

REEL DIMENTION (FREE)

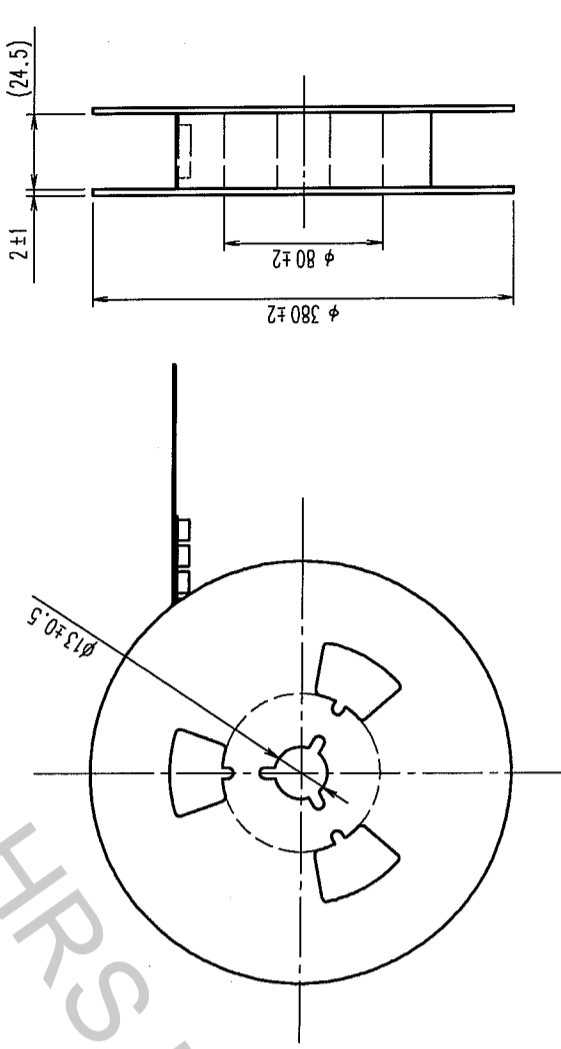

NOTE 1 THE DIMENSIONS IN PARENTHESES ARE FOR REFERENCE.  
2 PER REEL : 2500 CONNECTORS.

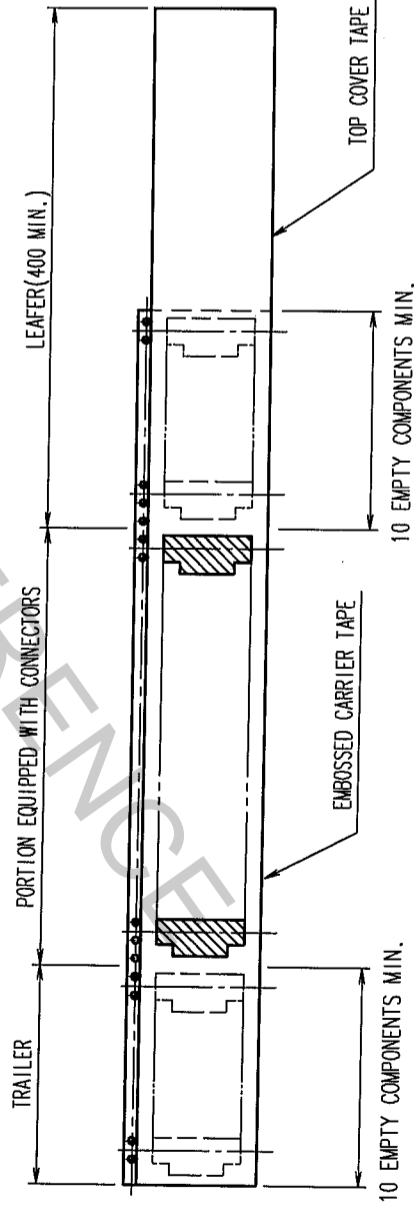

2	POLYESTER		4	
1	POLYSTYRENE	FINISH, REMARKS	3	(CONNECTOR)
NO.	MATERIAL	FINISH, REMARKS	NO.	MATERIAL
CODE NO. (OLD)		DRAWN	DESIGNED	CHECKED
		T.Shibuya	T.Shibuya	R. Takayama
		04.11.24	04.11.24	04.11.29
		PART NO.		RELEASED
DRAWING NO.		FH23-23S-0.3SHW(05)		
EDC3-153988-02				
SCALE				
2 : 1				
UNITS				
mm				
		CODE NO.		
		CL586-1324-5-05		
		FORM NO. 229 (FH)		

TO	
NC	