

1	2	3	4						
COUNT	DESCRIPTION OF REVISIONS	BY	CHKD	DATE	COUNT	DESCRIPTION OF REVISIONS	BY	CHKD	DATE
△					△				
△					△				
△					△				

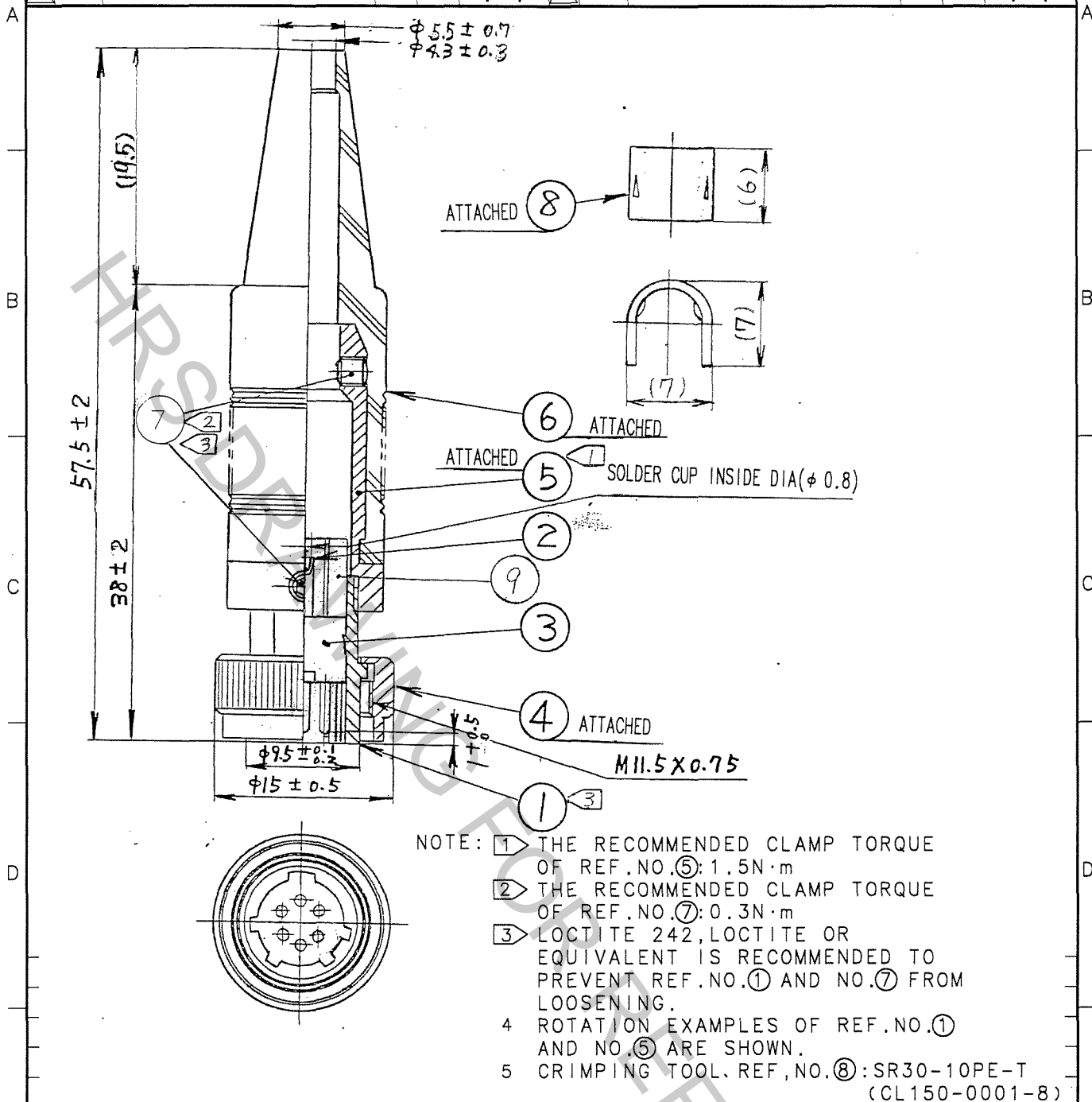

NOTE: ① THE RECOMMENDED CLAMP TORQUE OF REF.NO.⑤: 1.5N·m
 ② THE RECOMMENDED CLAMP TORQUE OF REF.NO.⑦: 0.3N·m
 ③ LOCTITE 242, LOCTITE OR EQUIVALENT IS RECOMMENDED TO PREVENT REF.NO.① AND NO.⑦ FROM LOOSENING.
 4 ROTATION EXAMPLES OF REF.NO.① AND NO.⑤ ARE SHOWN.
 5 CRIMPING TOOL, REF,NO.⑧: SR30-10PE-T (CL150-0001-8)

5	BRASS	NICKEL PLATING			
4	BRASS	CHROME PLATING	9	PTFE	(WHITE)
3	POLYACETAL	(WHITE)	8	BRASS	
2	BRASS	SURFACE PLATING : GOLD PLATED 0.2μm. UNDER PLATING : NICKEL PLATED 3μm.	7	STEEL	NICKEL PLATING JIS B 1177 N2.6x0.45x2
1	ZINC ALLOY	NICKEL PLATING	6	CR	(BLACK)
NO.	MATERIAL	FINISH, REMARKS	NO.	MATERIAL	FINISH, REMARKS

CODE NO. (OLD)	DRAWN	DESIGNED	CHECKED	APPROVED	RELEASED
	E.Yumino	E.Yumino	H.Zemba	M.Sato	
	05.11.10	05.11.10	05.11.15	05.11.15	

	DRAWING NO.	PART NO.		
	EDC4-009239-71	SR30-10PQ-6P(71)		
SCALE	CODE NO.			
2 : 1	CL103-0313-3-71			
UNITS				
mm	<table border="1"> <tr> <td>1</td> <td>1</td> </tr> </table>		1	1
1	1			

TO
R