

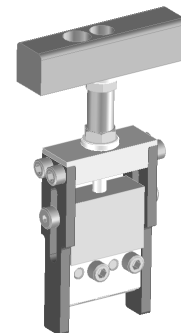

EXTreme PowerMass™ Vertical Receptacle Power Terminal Removal Tool Instruction Sheet Order No. 62100-5900



FEATURES

- % This tool is designed to remove the power terminals from the PC board after the connector housing is removed.
- % Removes terminals without damage to the board or holes.

SCOPE

Products: EXTreme PowerMass™ Vertical Receptacle Assemblies. See Product List below for specific part numbers.

Product List

The following is a partial list of the product order numbers and their specifications this tool is designed to run. Updates to this list are available on www.molex.com.

| Series No. | Connector Order No. | Description |
|------------|---------------------|--|
| 75545 | 75545-1000 | 80A Receptacle Assembly, tin tails |
| | 75545-1001 | 80A Receptacle Assembly, tin-lead tails |
| | 75545-1100 | 40A Receptacle Assembly, tin tails |
| | 75545-1101 | 40A Receptacle Assembly, tin-lead tails |
| | 75545-5100 | 40A Receptacle Assembly, tin tails |
| | 75545-5101 | 40A Receptacle Assembly, tin-lead tails |
| 75542 | 75542-1000 | 150A Receptacle Assembly, tin tails |
| | 75542-1001 | 150A Receptacle Assembly, tin-lead tails |
| | 75542-5000 | 150A Receptacle Assembly, tin tails |
| | 75542-5001 | 150A Receptacle Assembly, tin-lead tails |

DESCRIPTION

The Power Terminal Removal Tool clamps a pair of power terminals against an anvil then lifts the terminals out of the PCB using a screw-driven slide. The Terminal Removal Tool is shipped with the terminal clamp plates in the closed position, as shown in Figure 1.

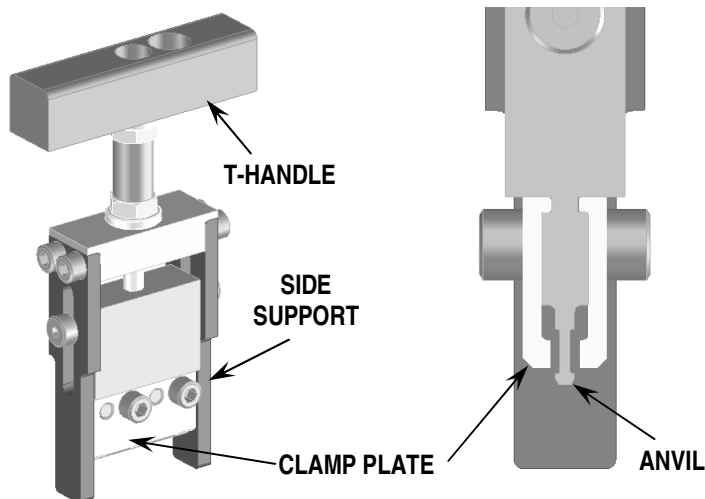

Figure 1

OPERATION

Note: Be sure that all parts of the Removal Tool will clear any components on the printed circuit board during use. Tape may also be placed over circuit traces or on the bottom of the side supports for added protection of the printed circuit board.

1. Remove the connector housing by gripping it with a pair of pliers and pulling it up from the terminals. See Figure 2.

Caution: Care must be taken during this procedure to prevent bending of the terminals that are left in place in the printed circuit board.

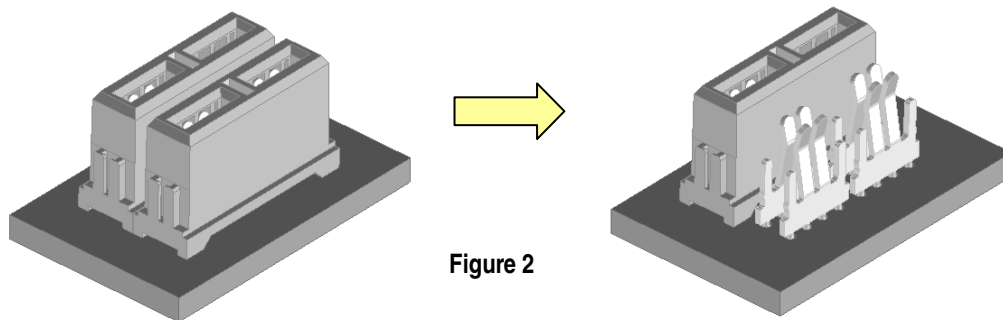

Figure 2

2. Using a 7/64" hex key, loosen the #6 SHCS holding the clamp plates. See Figure 3.
3. Before placing the Terminal Removal Tool into the terminals make sure the anvil is lowered. See Figure 3.
4. Position the Anvil Block between terminal rows. The clamp plate bottom rests on top of the terminal shoulder. See Figure 4.
5. Using a 7/64" hex key, tighten the (2) clamp plates. The clamp plates fit into a key slot in the anvil. Tighten the #6 SHCS so that the clamp plates "bite" into the terminals. Do not over tighten. See Figure 4.

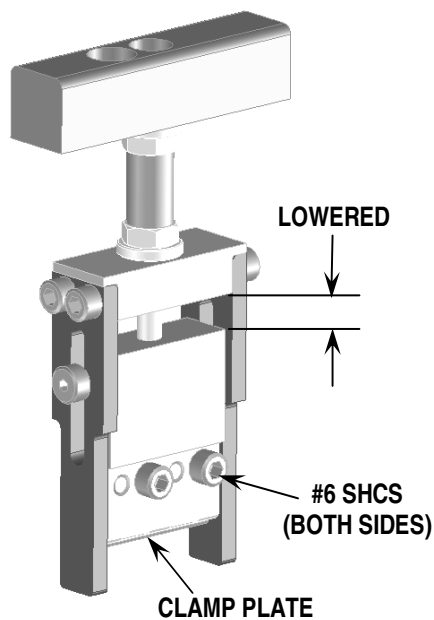

Figure 3

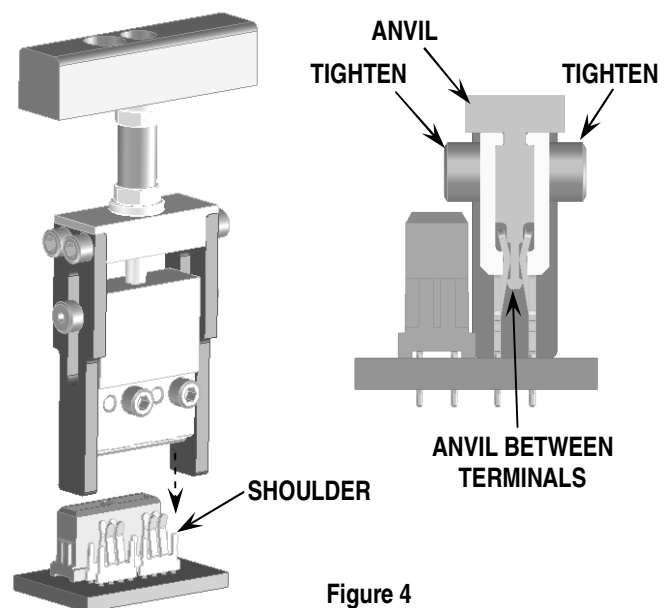

Figure 4

6. Position the Terminal Removal Tool so that the (2) side supports are resting on the printed circuit board.
7. Turn T-handle clockwise, making sure the threaded shaft goes into the threaded hole on top of the anvil.
8. Continue turning the T-Handle until the terminals lift up and are removed from the printed circuit board. See Figure 5.
9. Move the Removal Tool away from the printed circuit board. Then remove the terminals from the Removal Tool by loosening the #6 SHCS on the clamp plates and pulling out the terminals.
10. Extracted terminals should be discarded and not reused.

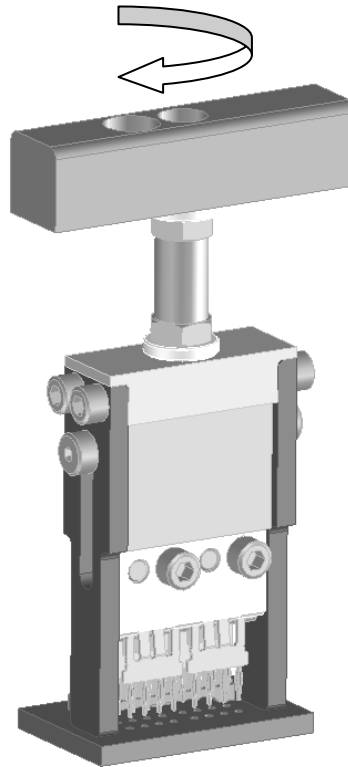

Figure 5

Maintenance

It is recommended that each operator of the tool be made aware of, and responsible for, the following maintenance steps:

1. Remove dust, moisture, and other contaminants with a clean brush, or soft, lint free cloth.
2. Do not use any abrasive materials that could damage the tool.
3. Make certain all pins; pivot points and bearing surfaces are protected with a thin coat of high quality machine oil. Do not oil excessively.
4. When tool is not in use, store in a clean, dry area.

CAUTION: Molex specifications are valid only when used with Molex terminals, applicators and tooling.

PARTS LIST

| Item | Order No | Description | Quantity |
|------|-------------------|---|-----------------|
| | 62100-5900 | EXTreme PowerMass™ Terminal Removal Tool | Figure 6 |
| 1 | 62100-5401 | Spacer Plate | 1 |
| 2 | 62100-5404 | T Handle | 1 |
| 3 | 62100-5903 | Anvil Block | 1 |
| 4 | 62100-5906 | Terminal Clamp Plate | 2 |
| 5 | 62100-5908 | Side Plate Guide | 2 |
| 6 | 63700-4308 | Shoulder Screw | 2 |
| 7 | 63700-4312 | Collar | 1 |
| 8 | 63700-4313 | Retainer | 1 |
| 9 | N/A | #8-32UNC Hex Nut | 2** |
| 10 | N/A | #8-32UNC by 2" long set screw | 1** |
| 11 | N/A | #6-32UNC by 3/8 long SHCS | 4** |
| 12 | N/A | #6-32UNC by 1/4 long SHCS | 4** |
| 13 | N/A | #8 Hardened Washer | 2** |

** Available from an industrial supply company such as MSC (1-800-645-7270).

Assembly Drawing

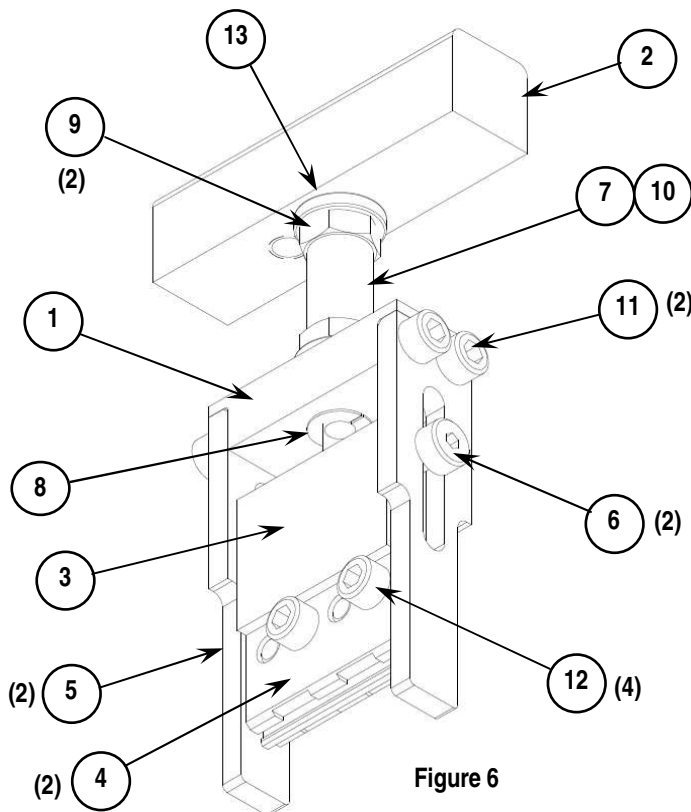

Americas Headquarters
 Lisle, Illinois 60532 U.S.A.
 1-800-78MOLEX
 amerinfo@molex.com

Far East North Headquarters
 Yamato, Kanagawa, Japan
 81-462-65-2324
 feninfo@molex.com

Far East South Headquarters
 Jurong, Singapore
 65-6-268-6868
 fesinfo@molex.com

European Headquarters
 Munich, Germany
 49-89-413092-0
 eurinfo@molex.com

Corporate Headquarters
 2222 Wellington Ct.
 Lisle, IL 60532 U.S.A.
 630-969-4550
 Fax: 630-969-1352

Visit our Web site at <http://www.molex.com>