

**AMP★ HOUSING WING
REMOVAL AND REPLACEMENT TOOL 266233-1
FOR USE WITH
ZERO INSERTION FORCE (ZIF)
LINEAR CARD-EDGE CONNECTORS**

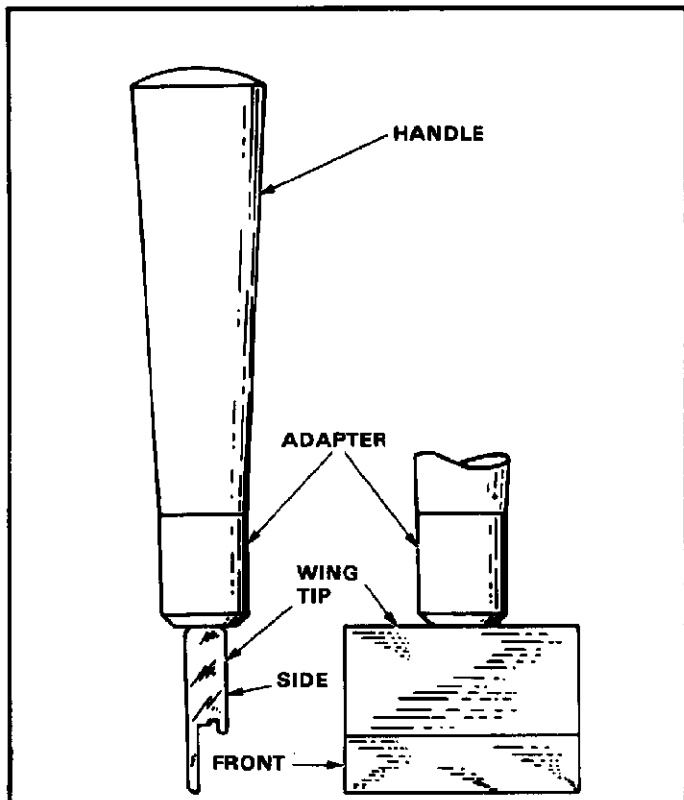

TYPE OF WING	PART NUMBER	NO. OF POSN
Left Closed End/No End	119936-1	20
	-2	25
	-3	30
Right Closed End/No End	119937-1	20
	-2	25
	-3	30
No End/No End	119938-1	15
	-2	20
	-3	25
	-4	30

NOTE: HANDLE, ADAPTER, AND WING TIP ARE THREADED REPLACEABLE PARTS.

Fig. 1

1. INTRODUCTION

AMP Housing Wing Removal and Replacement Tool 266233-1, used with Zero Insertion Force (ZIF) Linear Card-Edge Connectors, is designed to remove and to replace the wings of ZIF connector housing assemblies. The wings, listed by part number in Figure 1, must be removed in order to replace contacts, cams, handles, or housing modules when repairing a ZIF connector that is seated on a printed circuit (pc) board or panel.

Read this material thoroughly before starting.

2. DESCRIPTION

Each tool consists of three replaceable parts: a plastic handle, a threaded metal adapter, and a metal wing tip.

tip. The adapter screws into the handle. The wing tip, with its threads being cemented during assembly, screws onto the adapter. If the wing tip becomes dislodged, it is recommended that the threads of the replacement tip be cemented during re-assembly.

The wing tip of the tool is shown in Figure 2 in position for removing one of the wings. The ZIF connector module is shown in cross section seated on a pc board or panel.

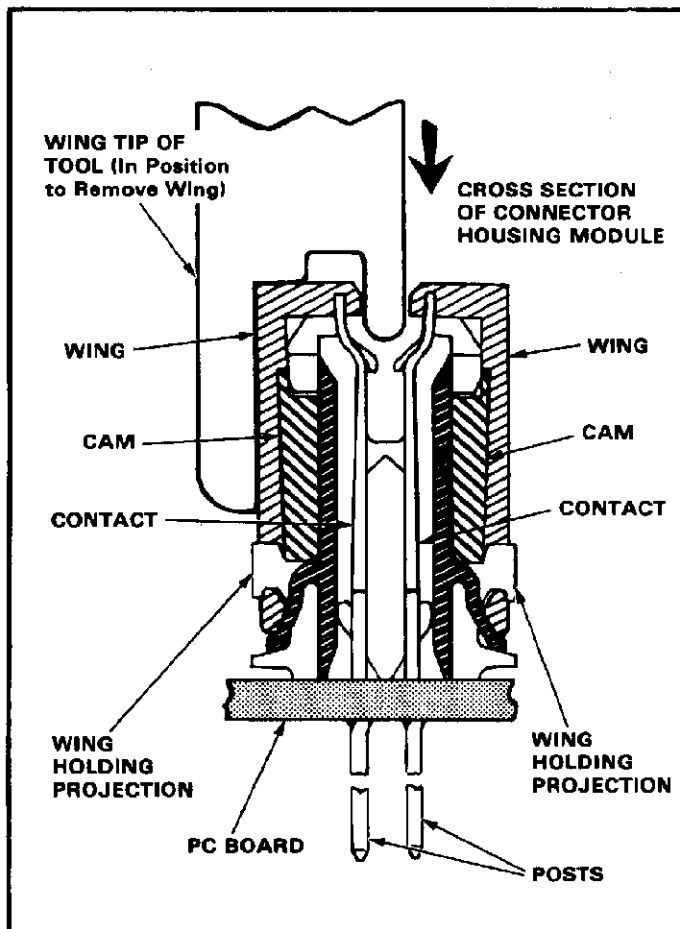

Fig. 2

3. WING REMOVAL

The connector housing assembly wings must be removed to repair the connector. Refer to Figure 3, and proceed as follows:

1. Place wing tip of tool over wing to be removed (see Figures 2 and 3A).
2. Rotate tool away from housing module (Figure 3B) and push down (Figure 3C).
3. Rotate tool back toward card slot (Figure 3D), releasing wing from housing module. Lift tool and wing from housing module and then remove wing from tool.

Copyright 1983, 1986 by AMP Incorporated, Harrisburg, Pa. All International Rights Reserved. AMP Incorporated products covered by U.S. and Foreign patents and/or patents pending.

WING REMOVAL

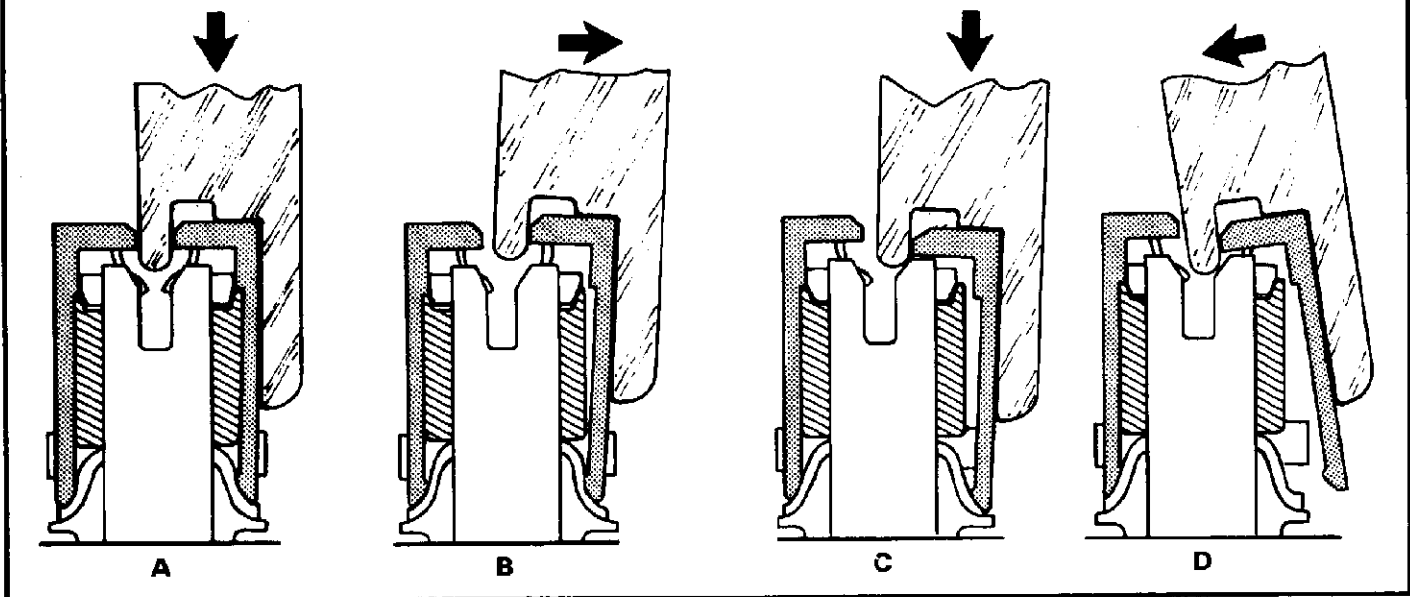

Fig. 3

4. WING REPLACEMENT

After completing the connector repair, the housing module wings can be replaced one at a time, as shown in Figure 4. It is important that the square holes in the wing align with the wing holding projections as shown in Figure 5. Proceed as follows:

WING REPLACEMENT

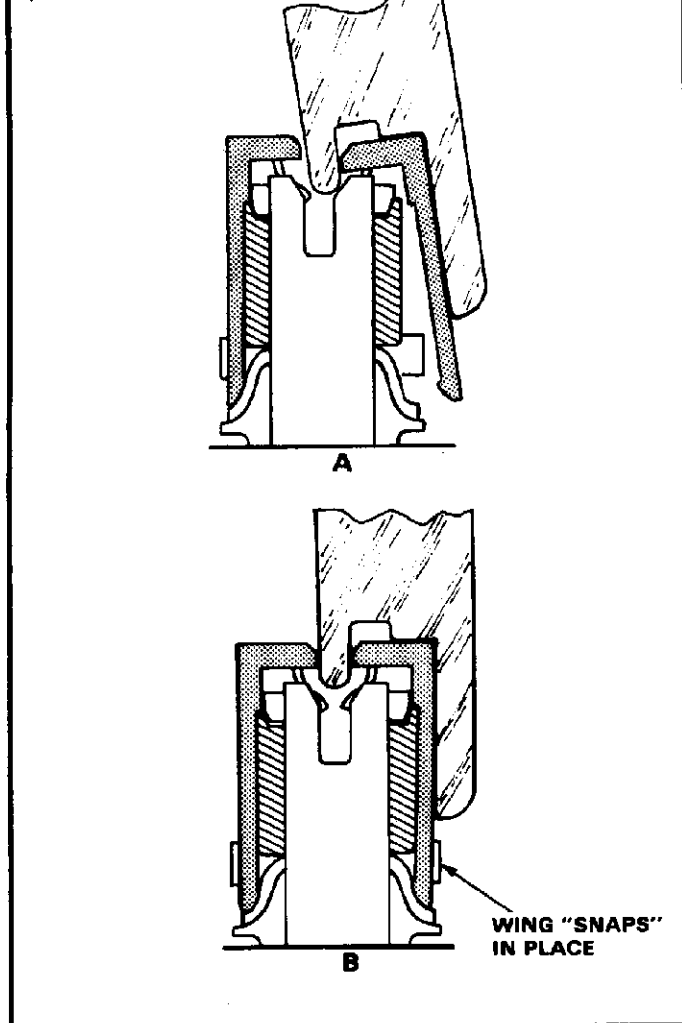

Fig. 4

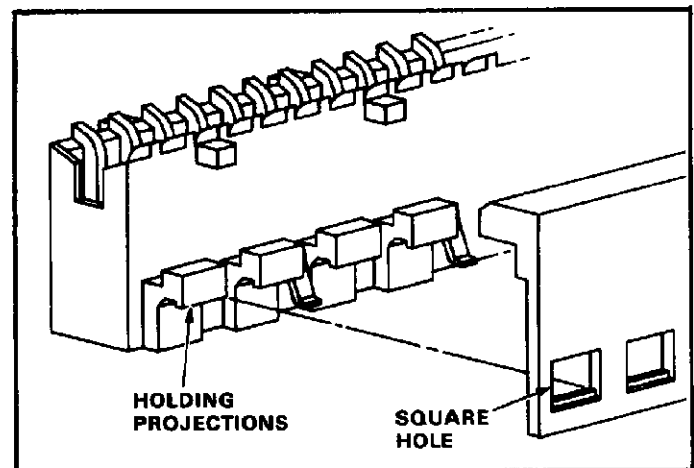

Fig. 5

1. Place wing on housing module with contacts properly set in wing circuit holes.
2. Place tool on wing (Figure 4A), push down, and rotate tool as indicated in Figure 4A until openings in wing engage with wing holding projections and wing "snaps" into place on housing module (Figure 4B). The square holes in the wing must align with the wing holding projections as shown in Figure 5. Lift tool straight up to remove tool.
3. When all wings are replaced, actuate cams to check connector for proper operation.

5. TOOL CERTIFICATION

The tooling is assembled and certified before shipment. AMP recommends that the tool be inspected immediately upon its arrival and at regularly scheduled intervals to ensure that it has not been damaged during handling and operation.

and replacement parts may be purchased by sending a request to:

AMP Incorporated
 P.O. Box 3608
 Harrisburg, PA 17105-3608

NOTE

The threads of the wing tip are treated with a cement that will soften when heat is applied. This will allow separation of the wing tip and adapter when component replacement is necessary.

6. TOOL REPAIR

All of the components listed in Figure 6 are customer-replaceable by qualified personnel. Additional tooling

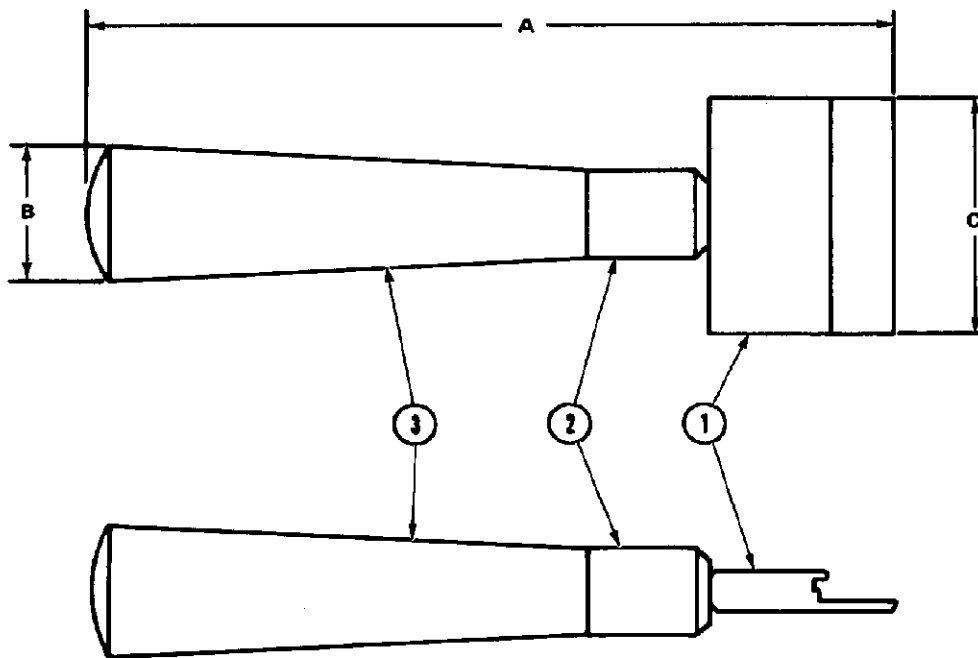

ITEM	PART NUMBER	DESCRIPTION	QUANTITIES REQUIRED			
1	311536-1	Wing Tip	1			
2	311536-1	Adapter	1			
3	27152-2	Handle	1			
TOOL SPECIFICATIONS						
PART NUMBER	DIMENSIONS (In.)			WEIGHT (Approx)	ENGINEERING APPROVAL	DATE
	A	B	C			
266233-1	6.38	1.12	2.00	4.0 oz	George Hoover	1-2-86

Fig. 6