

THIS DRAWING IS UNPUBLISHED. RELEASED FOR PUBLICATION ,19 .
 © COPYRIGHT 19 BY AMP INCORPORATED. ALL RIGHTS RESERVED.

LOC	DIST	REVISIONS					
		P	LTR	DESCRIPTION	DATE	DWN	APVD
G	14		M	REV PER 0G3A-0529-01	28SEP01	JR	MJS

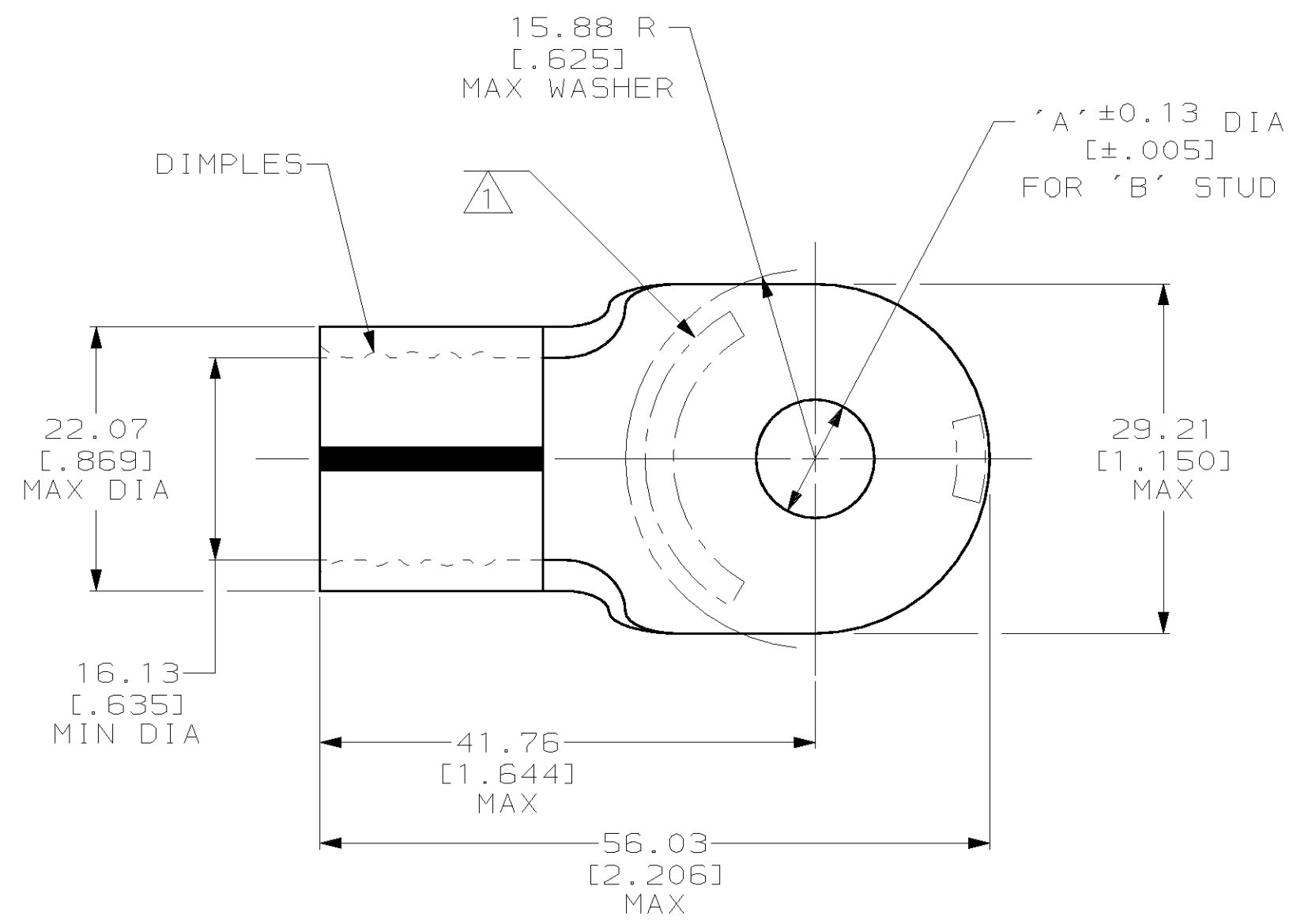

AMP WIRE RANGE	UL E13288 Listed
4/0 AWG SOLID OR STRANDED	4/0 AWG SOLID OR STRANDED
SF LR7189 Certified	MILITARY P/N AND CLASS
4/0 AWG SOLID OR STRANDED	NOT APPLICABLE

- ① STAMP AMP 4/OW* 200 APPROX AS SHOWN
- ② MATERIAL THK: 2.59 ±0.08 [.102 ±.003]
- ③ TIN PL 0.00254 [.000100] MIN THK PER ASTM B 545
- ④ NICKEL PL 0.00762 [.000300] MIN THK PER QQ-N-290
- ⑤ SEE RESTRICTED CUSTOMER DRAWING 2-36932-5
- ⑥ SEE RESTRICTED CUSTOMER DRAWING 2-36932-6

OBSOLETE	9.91 [.390]	3/8	④ -	2-36932-7
⑥	-	-	-	2-36932-6
⑤	-	-	-	2-36932-5
	6.73 [.265] ^{+0.38 [.015]} _{-0.13 [.005]}	1/4	③ -	2-36932-2
	9.91 [.390]	3/8	③ -	36932
	'A'	'B'	FINISH	AMP PART NUMBER

AMP INCORPORATED
CUSTOMER SERVICE SYSTEMS

FOR ADDITIONAL PRODUCT INFORMATION OR COPIES OF DRAWINGS AND TECHNICAL DOCUMENTS	PRODUCT INFORMATION CENTER 1-800-522-6752	RECOMMENDED OPERATING TEMPERATURE: 170°C MAX
FOR APPLICATION TOOLING INFORMATION	TOOLING ASSISTANCE CENTER 1-800-722-1111	VOLTAGE RATING: NOT APPLICABLE
FOR ORDER ENTRY	1-800-526-5142	WIRE CROSS SECTIONAL AREA RANGE: 96.3-117.0mm ² [190,000-231,100] CIR MILS STRANDED

THIS DRAWING IS A CONTROLLED DOCUMENT FOR AMP INCORPORATED. IT IS SUBJECT TO CHANGE AND THE CONTROLLING ENGINEERING ORGANIZATION SHOULD BE CONTACTED FOR THE LATEST REVISION.

DIMENSIONS: mm [INCHES]	TOLERANCES UNLESS OTHERWISE SPECIFIED:
	0 PLC ±-
	1 PLC ±-
	2 PLC ±0.20 [.008]
	3 PLC ±-
	4 PLC ±-
	ANGLES ±-
MATERIAL COPPER PER ASTM B-152 ANNEALED	FINISH -

DWN DK SCHRUM 15MAY96	AMP AMP Incorporated Harrisburg, PA 17105-3608
CHK DM SWARTZ 01JUL96	
APVD JL MECKLEY 01JUL96	
PRODUCT SPEC	
APPLICATION SPEC	NAME TERMINAL, RING TONGUE, SOLISTRAND
WEIGHT -	SIZE A3
CUSTOMER DRAWING	CAGE CODE 00779
	DRAWING NO C-36932
	SCALE 2:1
	SHEET 1 OF 1
	REV M