

1. PRESS FIT LEGS 2.28mm [0.090"]
2. SINGLE SIDED BOARD THICKNESS
 NOMINAL: 1.60 [0.062"]
 MINIMUM: 1.44 [0.057"]
 BELLY TO BELLY BOARD THICKNESS
 NOMINAL: 2.30 [0.090"]
 MINIMUM: 2.07 [0.081"]
3. REFERENCE DOCUMENTS:
 PRODUCT SPECIFICATION: XFP MSA
4. THIS PRODUCT MEETS THE RESTRICTION OF HAZARDOUS SUBSTANCES IN ELECTRICAL AND ELECTRONIC EQUIPMENT (RoHS) DIRECTIVE (2009/95/EC).

ADDED NOTE PG 2 EC NO: USY2011-0301 DRAWN: JERWIN CHECKED: CHIRSCHY APPROVED: RAHMOOD DATE: 2010/03/10	QUALITY SYMBOLS ▽=0 ▽=0	GENERAL TOLERANCES (UNLESS SPECIFIED)		DIMENSION STYLE	SCALE	DESIGN UNITS	THIRD ANGLE PROJECTION	
				MM ONLY	3:1	METRIC		
				DRAWN BY DATE		TITLE		
				JERWIN 2008/09/10		XFP CAGE ASSEMBLY W/ INSULATING TAPE		
		CHECKED BY DATE		MATERIAL NO.			DOCUMENT NO.	
		CHIRSCHY 2008/08/10		747360451		SD-74736-0451		
		APPROVED BY DATE		SIZE		SHEET NO.		
		RAHMOOD 2010/11/23		D THIS DRAWING CONTAINS INFORMATION THAT IS PROPRIETARY TO MOLEX INCORPORATED AND SHOULD NOT BE USED WITHOUT WRITTEN PERMISSION		1 OF 3		
		DRAFT WHERE APPLICABLE MUST REMAIN WITHIN DIMENSIONS						

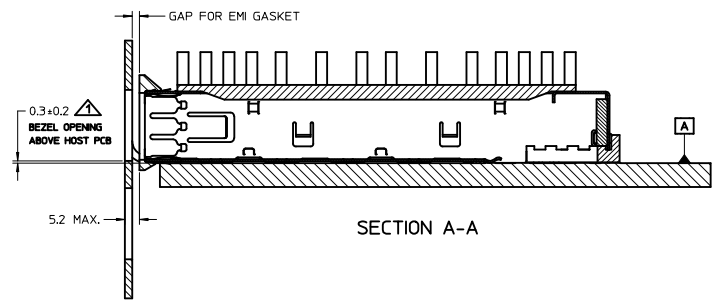
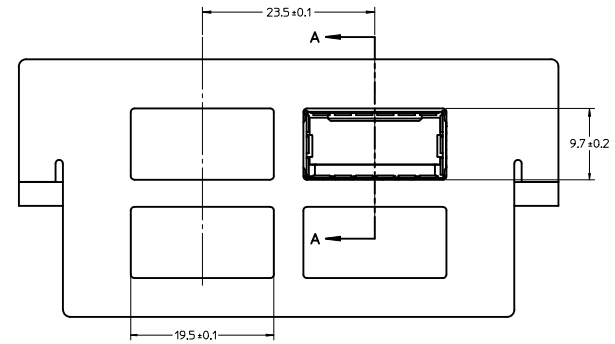
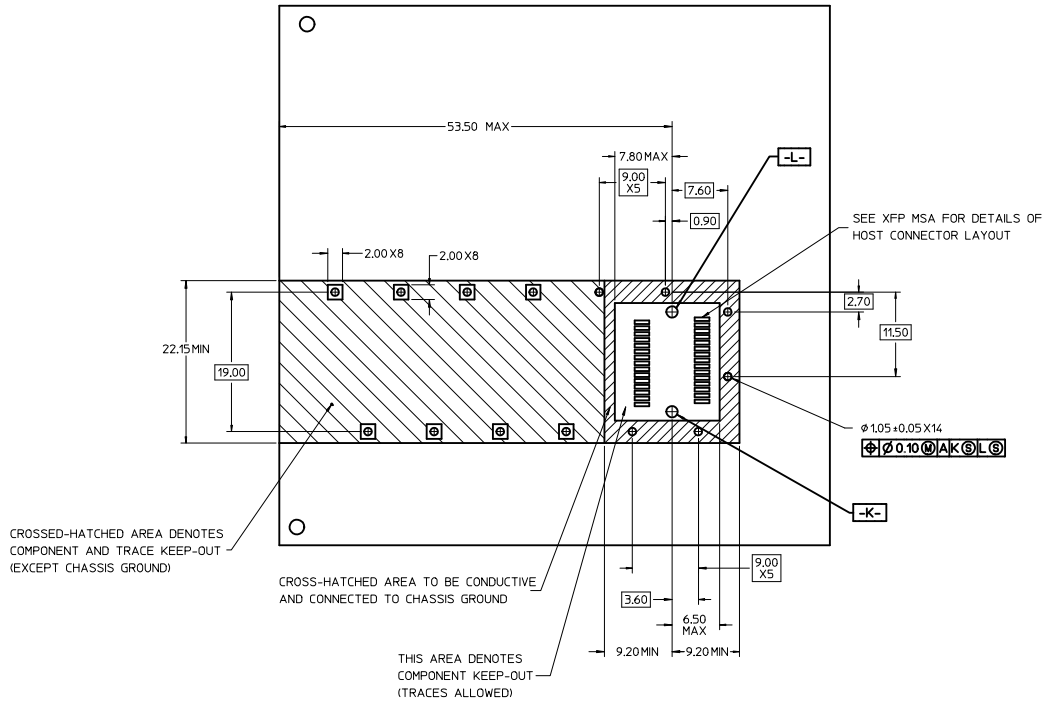

▲ FOR PCI APPLICATIONS RECOMMENDED DIMENSION IS 0.4 ± 0.1

CROSSED-HATCHED AREA DENOTES COMPONENT AND TRACE KEEP-OUT (EXCEPT CHASSIS GROUND)

CROSS-HATCHED AREA TO BE CONDUCTIVE AND CONNECTED TO CHASSIS GROUND

ADDED NOTE PG 2 EC NO: USY2011-0301 DRAWN: JERWIN 2010/03/01 CHKD: CHIRSCHY APPR: RAHMOOD 2010/11/23	QUALITY SYMBOLS	GENERAL TOLERANCES (UNLESS SPECIFIED)	DIMENSION STYLE	SCALE	DESIGN UNITS	THIRD ANGLE PROJECTION
	▽=0 ▽=0	mm INCH 4 PLACES ± --- ± --- 3 PLACES ± --- ± --- 2 PLACES ± 0.10 ± --- 1 PLACE ± 0.25 ± --- ANGULAR ± 1°	MM ONLY	3:1	METRIC	TITLE: XFP CAGE ASSEMBLY W/ INSULATING TAPE MATERIAL NO: 747360451 DOCUMENT NO: SD-74736-0451
	DRAFT WHERE APPLICABLE MUST REMAIN WITHIN DIMENSIONS	DRAWN BY: JERWIN CHECKED BY: CHIRSCHY APPROVED BY: RAHMOOD	DATE: 2008/09/10 DATE: 2008/08/10 DATE: 2010/11/23	MOLEX INCORPORATED	SHEET NO: 2 OF 3	
	THIS DRAWING CONTAINS INFORMATION THAT IS PROPRIETARY TO MOLEX INCORPORATED AND SHOULD NOT BE USED WITHOUT WRITTEN PERMISSION					

DATE	REV	DESCRIPTION
2008/09/10	A	1. INITIAL RELEASE
2009/05/07	B	1. REMOVED ISO VIEW FROM PAGE 1
		2. ADDED NOTES TO PAGE 1
		3. REMOVED NOTE 2 FROM PAGE 2
		4. REMOVED NOTE 3 FROM PAGE 1 AND RENUMBERED REMAINING NOTES
2010/03/01	C	1. ADDED NOTE - THIS AREA DENOTES COMPONENT KEEP-OUT (TRACES ALLOWED) PAGE 2.

REMOVED ISO VIEW IEC NO. USY2011-0301 DRAWN: JERWIN 2010/03/01 CHECKED: CHYKX/CHRSCHY APPROVED: RMAHMOOD 2010/11/23	QUALITY SYMBOLS	GENERAL TOLERANCES (UNLESS SPECIFIED)	DIMENSION STYLE	SCALE	DESIGN UNITS	THIRD ANGLE PROJECTION															
	▽=0 ▽=0	<table border="1"> <tr> <th></th> <th>mm</th> <th>INCH</th> </tr> <tr> <td>4 PLACES</td> <td>±---</td> <td>±---</td> </tr> <tr> <td>3 PLACES</td> <td>±---</td> <td>±---</td> </tr> <tr> <td>2 PLACES</td> <td>±0.10</td> <td>±---</td> </tr> <tr> <td>1 PLACE</td> <td>±0.25</td> <td>±---</td> </tr> </table> ANGULAR ± 1°		mm	INCH	4 PLACES	±---	±---	3 PLACES	±---	±---	2 PLACES	±0.10	±---	1 PLACE	±0.25	±---	MM ONLY DRAWN BY: JERWIN DATE: 2008/09/10 CHECKED BY: CHRSCHY DATE: 2008/08/10 APPROVED BY: RMAHMOOD DATE: 2010/11/23	1:1	METRIC	TITLE: XFP CAGE ASSEMBLY W/ INSULATING TAPE MOLEX INCORPORATED
		mm	INCH																		
	4 PLACES	±---	±---																		
3 PLACES	±---	±---																			
2 PLACES	±0.10	±---																			
1 PLACE	±0.25	±---																			
DRAFT WHERE APPLICABLE MUST REMAIN WITHIN DIMENSIONS	MATERIAL NO. 747360451 DOCUMENT NO. SD-74736-0451	SHEET NO. 3 OF 3																			
SIZE D	THIS DRAWING CONTAINS INFORMATION THAT IS PROPRIETARY TO MOLEX INCORPORATED AND SHOULD NOT BE USED WITHOUT WRITTEN PERMISSION																				

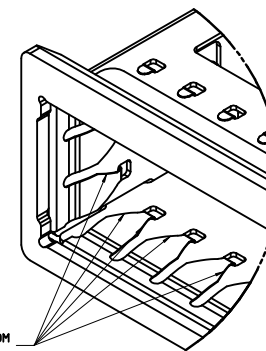
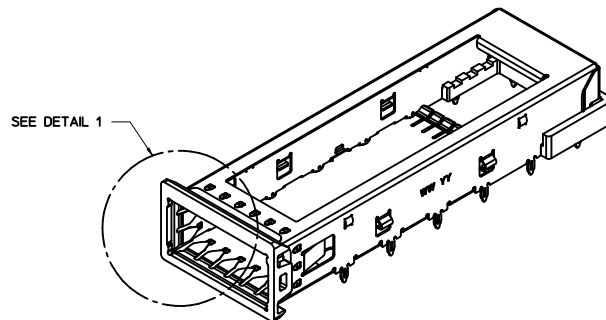
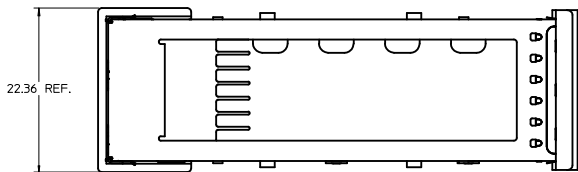

DETAIL 1
SCALE 8:1

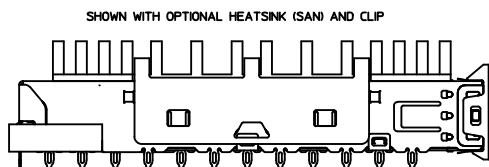
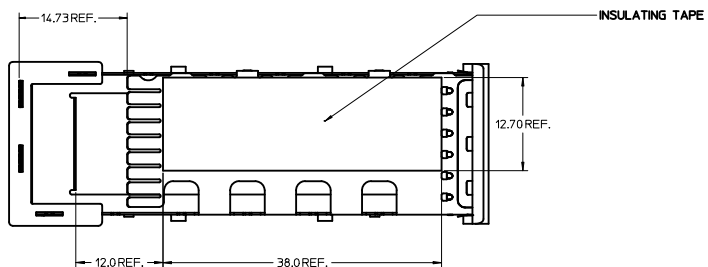
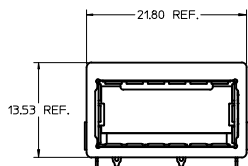
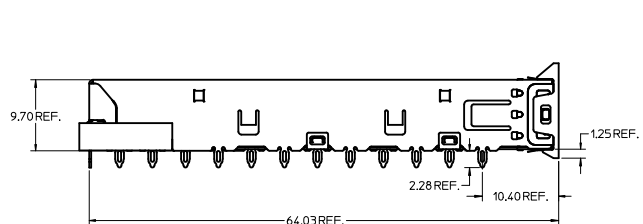

1. PRESS FIT LEGS 2.28mm [0.090"]
2. SINGLE SIDED BOARD THICKNESS
 NOMINAL: 1.60 [0.062"]
 MINIMUM: 1.44 [0.057"]
 BELLY TO BELLY BOARD THICKNESS
 NOMINAL: 2.30 [0.090"]
 MINIMUM: 2.07 [0.081"]
3. REFERENCE DOCUMENTS:
 PRODUCT SPECIFICATION: XFP MSA
4. THIS PRODUCT MEETS THE RESTRICTION OF HAZARDOUS SUBSTANCES IN ELECTRICAL AND ELECTRONIC EQUIPMENT (RoHS) DIRECTIVE (2009/95/EC).

INITIAL RELEASE EC NO: USY2011-0313 DRAWN: JERWIN 2010/11/03 CHECKED: CHRISCHY 2010/11/03 APPROVED: RMAHMOOD 2010/11/09	QUALITY SYMBOLS ▽=0 ▽=0	GENERAL TOLERANCES (UNLESS SPECIFIED)		DIMENSION STYLE MM ONLY		SCALE 3:1	DESIGN UNITS METRIC	THIRD ANGLE PROJECTION		
		4 PLACES ±.005 ±.005	3 PLACES ±.005 ±.005	2 PLACES ±.010 ±.010	1 PLACE ±.025 ±.025	mm INCH	DRAWN BY DATE JERWIN 2010/11/03	TITLE XFP CAGE ASSEMBLY W/ INSULATING TAPE		
		ANGULAR ± 1°				DRAFT WHERE APPLICABLE MUST REMAIN WITHIN DIMENSIONS		MOLEX INCORPORATED		
		MATERIAL NO. 747360452		DOCUMENT NO. SD-74736-0452		SHEET NO. 1 OF 3		THIS DRAWING CONTAINS INFORMATION THAT IS PROPRIETARY TO MOLEX INCORPORATED AND SHOULD NOT BE USED WITHOUT WRITTEN PERMISSION		

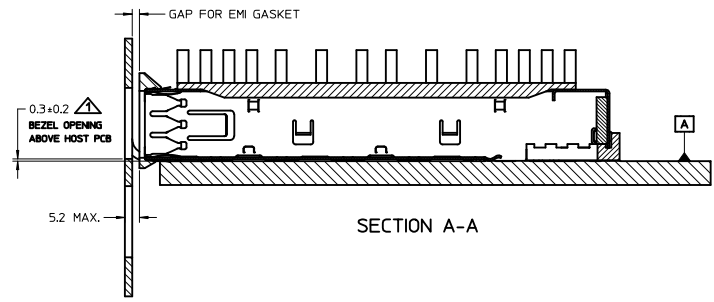
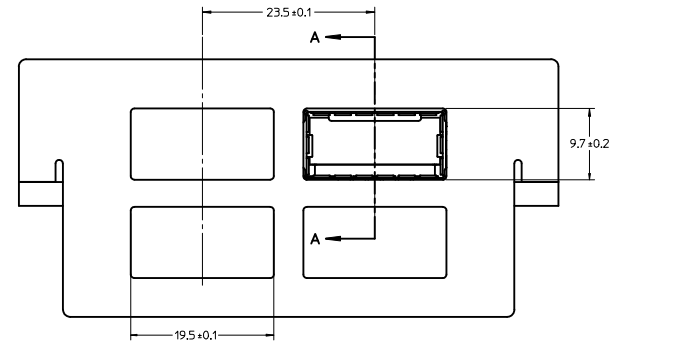
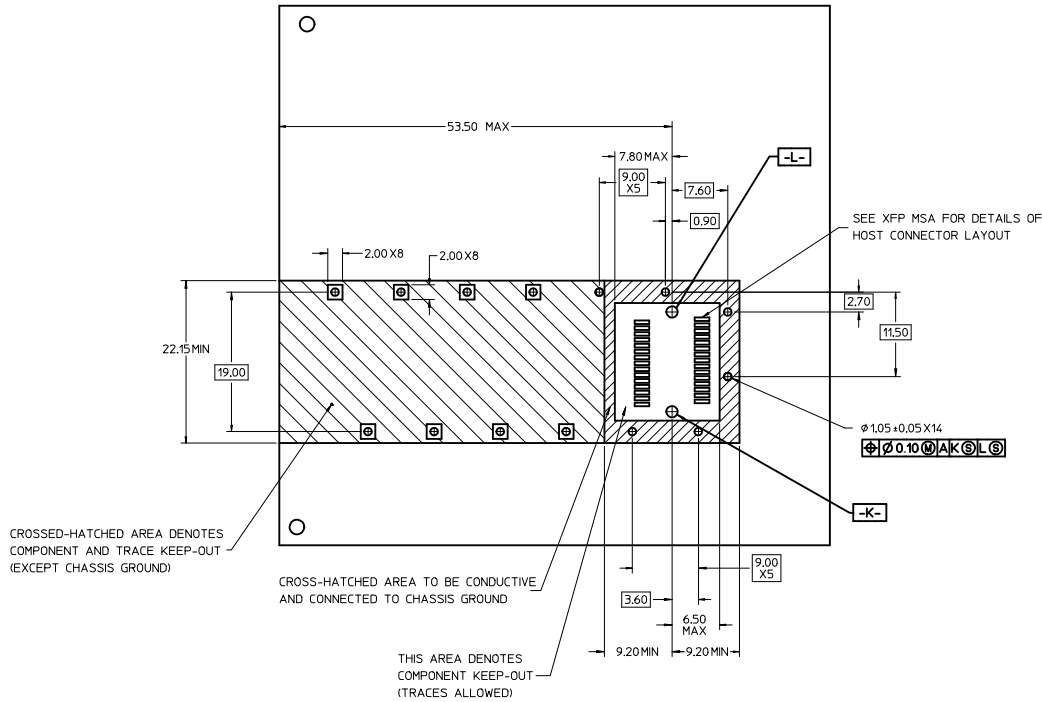

△ FOR PCI APPLICATIONS RECOMMENDED DIMENSION IS 0.4 ± 0.1

INITIAL RELEASE IEC NO: USYZ2011-0313 DRAWN: JERWIN 2010/11/03 CHKD: CHRSCHY 2010/11/03 APPR: RAHMOOD 2010/11/09	QUALITY SYMBOLS ▽=0 ▽=0	GENERAL TOLERANCES (UNLESS SPECIFIED)		DIMENSION STYLE MM ONLY	SCALE 3:1	DESIGN UNITS METRIC	THIRD ANGLE PROJECTION		
		4 PLACES ± --- ± ---	3 PLACES ± --- ± ---	2 PLACES ± 0.10 ± ---	1 PLACE ± 0.25 ± ---	DRAWN BY JERWIN	DATE 2010/11/03	TITLE XFP CAGE ASSEMBLY W/ INSULATING TAPE	
		ANGULAR ± 1 °				CHECKED BY CHRSCHY	DATE 2010/11/03	MOLEX INCORPORATED	
		DRAFT WHERE APPLICABLE MUST REMAIN WITHIN DIMENSIONS				APPROVED BY RAHMOOD	DATE 2010/11/09	MATERIAL NO. 747360452	DOCUMENT NO. SD-74736-0452
				SIZE D	THIS DRAWING CONTAINS INFORMATION THAT IS PROPRIETARY TO MOLEX INCORPORATED AND SHOULD NOT BE USED WITHOUT WRITTEN PERMISSION			SHEET NO. 2 OF 3	

20 19 18 17 16 15 14 13 12 11 10 9 8 7 6 5 4 3 2 1

DATE	REV	DESCRIPTION
2010/11/03	A	1. INITIAL RELEASE

INITIAL RELEASE IEC NO. USY2011-0313 DRAWN BY: JERWIN 2010/11/03 CHYK: CHIRSCHY 2010/11/03 APPR: MAHMOOD 2010/11/09	QUALITY SYMBOLS = 0 = 0	GENERAL TOLERANCES (UNLESS SPECIFIED) <table border="1"> <thead> <tr> <th></th> <th>mm</th> <th>INCH</th> </tr> </thead> <tbody> <tr> <td>4 PLACES</td> <td>± .005</td> <td>± .0004</td> </tr> <tr> <td>3 PLACES</td> <td>± .002</td> <td>± .0001</td> </tr> <tr> <td>2 PLACES</td> <td>± 0.10</td> <td>± .004</td> </tr> <tr> <td>1 PLACE</td> <td>± 0.25</td> <td>± .010</td> </tr> </tbody> </table> ANGULAR ± 1°		mm	INCH	4 PLACES	± .005	± .0004	3 PLACES	± .002	± .0001	2 PLACES	± 0.10	± .004	1 PLACE	± 0.25	± .010	DIMENSION STYLE MM ONLY	SCALE 1:1	DESIGN UNITS METRIC	THIRD ANGLE PROJECTION
		mm	INCH																		
	4 PLACES	± .005	± .0004																		
	3 PLACES	± .002	± .0001																		
2 PLACES	± 0.10	± .004																			
1 PLACE	± 0.25	± .010																			
DRAWN BY: JERWIN 2010/11/03 CHECKED BY: CHIRSCHY 2010/11/03 APPROVED BY: MAHMOOD 2010/11/09	MATERIAL NO. 747360452	TITLE XFP CAGE ASSEMBLY W/ INSULATING TAPE	MOLEX INCORPORATED	SHEET NO. 3 OF 3																	
DRAFT WHERE APPLICABLE MUST REMAIN WITHIN DIMENSIONS	SIZE D	DOCUMENT NO. SD-74736-0452	THIS DRAWING CONTAINS INFORMATION THAT IS PROPRIETARY TO MOLEX INCORPORATED AND SHOULD NOT BE USED WITHOUT WRITTEN PERMISSION																		

19 18 17 16 15 14 13 12 11 10 9 8 7 6 5 4 3 2 1

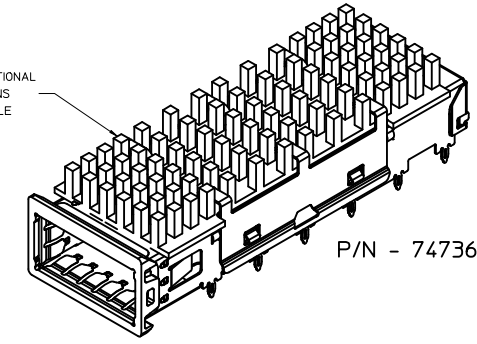
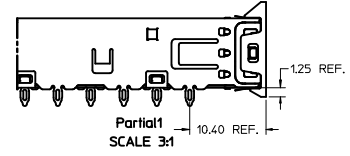
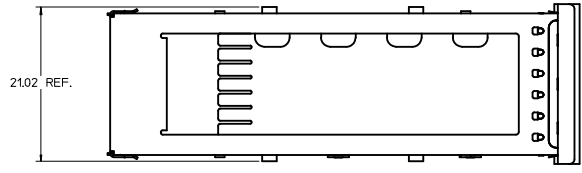

P/N - 747360212

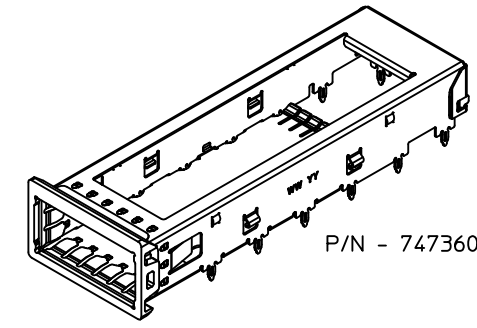

P/N - 747360210

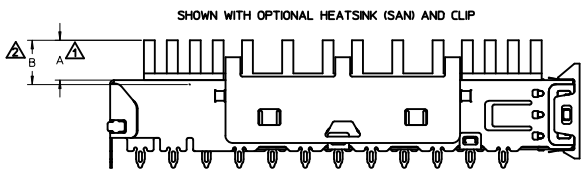
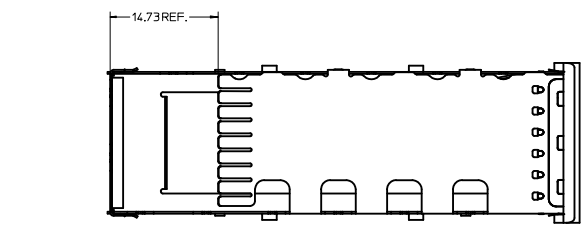
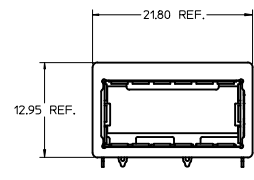
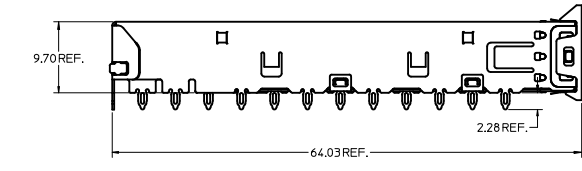

- ▲ MAXIMUM HEIGHT OF HEATSINK WITH MODULE INSERTED
- ▲ OVERALL HEIGHT OF HEATSINK
- 3. OTHER HEATSINK DESIGNS ARE AVAILABLE INCLUDING CUSTOM DESIGNS

PART NUMBER FOR XFP CAGE ASSEMBLY & PARTS (W/OUT ELASTOMER EMI GASKET)					
P/N	DIM A	DIM B	DESCRIPTION	POWER LEVEL	THERMAL RESISTANCE @200 LFM
747360210	N/A	N/A	XFP CAGE WITH NO HEATSINK OR CLIP	N/A	N/A
747360211	4.0	4.2	XFP CAGE WITH PCI HEATSINK	UP TO 1.5W	<18.0 C/W
747360212	6.3	6.5	XFP CAGE WITH SAN HEATSINK (SHOWN)	UP TO 2.5W	<11.5 C/W
747360213	13.3	13.5	XFP CAGE WITH TALL HEATSINK	UP TO 3.5W	<8.0 C/W
747360230	N/A	N/A	HEATSINK CLIP ONLY	N/A	N/A
747360240	N/A	N/A	PCI HEATSINK ONLY	UP TO 1.5W	<18.0 C/W
747360241	N/A	N/A	SAN HEATSINK ONLY	UP TO 2.5W	<11.5 C/W
747360242	N/A	N/A	TALL HEATSINK ONLY	UP TO 3.5W	<8.0 C/W

ADDED NOTE PG 2 EC NO: USY2011-0301 DRAWN BY: ERWIN 2010/06/07 CHECKED BY: CHYKCHIRSHY 2010/10/13 APPROVED BY: RAHMOOD 2010/11/23	QUALITY SYMBOLS ▽=0 ▽=0	GENERAL TOLERANCES (UNLESS SPECIFIED) <table border="1"> <tr> <th></th> <th>mm</th> <th>INCH</th> </tr> <tr> <td>4 PLACES</td> <td>±.00</td> <td>±.00</td> </tr> <tr> <td>3 PLACES</td> <td>±.01</td> <td>±.00</td> </tr> <tr> <td>2 PLACES</td> <td>±.02</td> <td>±.00</td> </tr> <tr> <td>1 PLACE</td> <td>±.05</td> <td>±.00</td> </tr> </table> ANGULAR ± 1°		mm	INCH	4 PLACES	±.00	±.00	3 PLACES	±.01	±.00	2 PLACES	±.02	±.00	1 PLACE	±.05	±.00	DIMENSION STYLE MM ONLY	SCALE 3:1	DESIGN UNITS METRIC	THIRD ANGLE PROJECTION
		mm	INCH																		
4 PLACES	±.00	±.00																			
3 PLACES	±.01	±.00																			
2 PLACES	±.02	±.00																			
1 PLACE	±.05	±.00																			
DRAWN BY: KLOYD 2004/12/02 CHECKED BY: BRUSSELL 2004/12/02 APPROVED BY: RAHMOOD 2010/11/23	DRAFT WHERE APPLICABLE MUST REMAIN WITHIN DIMENSIONS		MATERIAL NO. SEE CHART	DOCUMENT NO. SD-74736-210	TITLE XFP CAGE ASSEMBLY WITHOUT ELASTOMER EMI GASKET	SHEET NO. 1 OF 2															

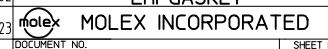

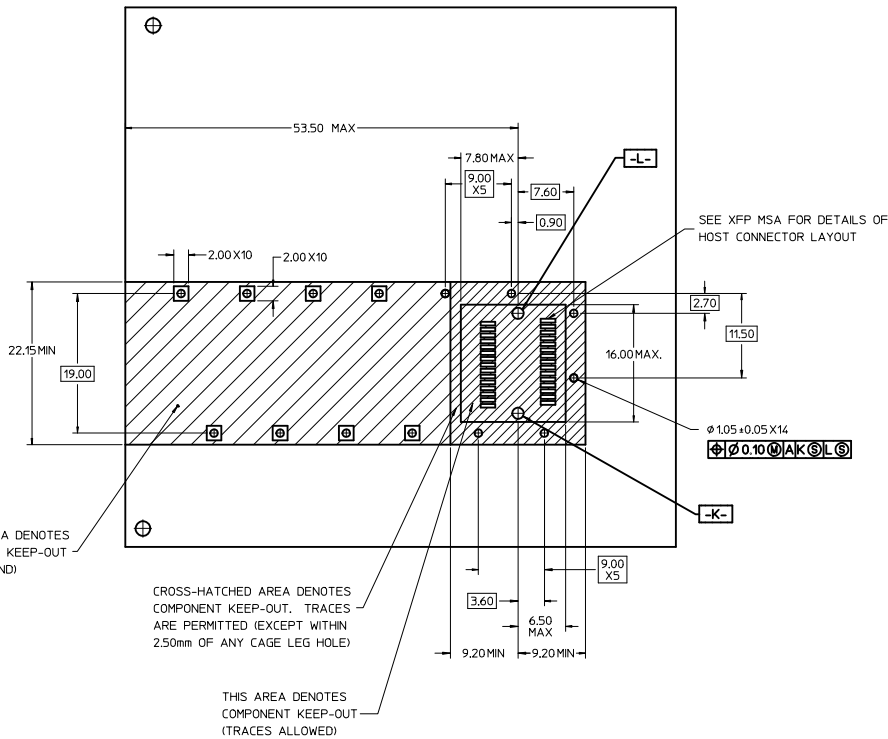

▲ FOR PCI APPLICATIONS RECOMMENDED DIMENSION IS 0.4 ± 0.1

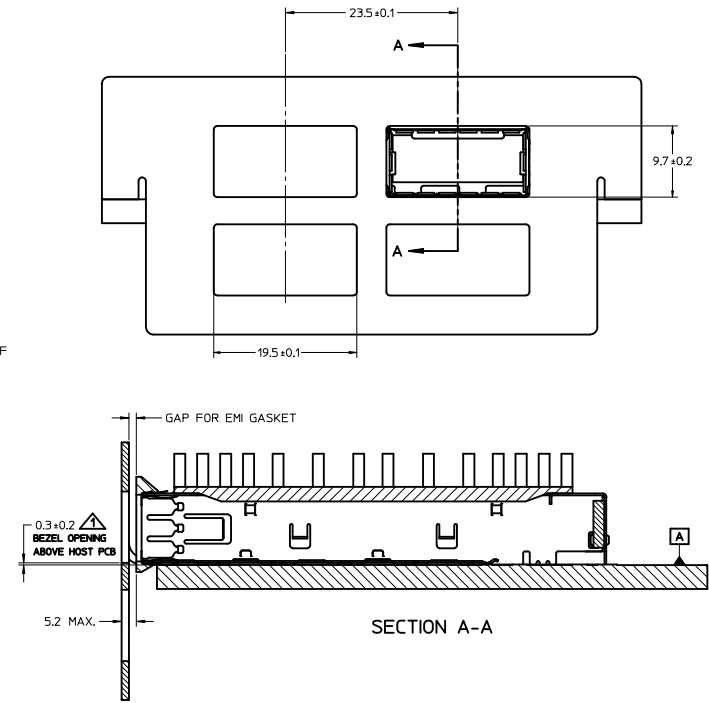

ADDED NOTE PG 2 ELEC NO: USYZ011-0301 DRAWN: LERMIN 2010/06/07 CHECKED: CHYKOLHIRSCHY 2010/10/13 APPROVED: RMAHMOOD 2010/11/23	QUALITY SYMBOLS ▽=0 ▽=0	GENERAL TOLERANCES (UNLESS SPECIFIED)		DIMENSION STYLE MM ONLY	SCALE 3:1	DESIGN UNITS METRIC	THIRD ANGLE PROJECTION			
		4 PLACES ± --- ± ---	3 PLACES ± --- ± ---	2 PLACES ± 0.10 ± ---	1 PLACE ± 0.25 ± ---	DRAWN BY K LLOYD	DATE 2004/12/02	CHECKED BY BRUSSELL	DATE 2004/12/02	TITLE XFP CAGE ASSEMBLY WITHOUT ELASTOMER EMI GASKET
		ANGULAR ± 1°		DRAFT WHERE APPLICABLE MUST REMAIN WITHIN DIMENSIONS		MATERIAL NO. SEE CHART	MOLEX INCORPORATED		SHEET NO. 2 OF 2	
		THIS DRAWING CONTAINS INFORMATION THAT IS PROPRIETARY TO MOLEX INCORPORATED AND SHOULD NOT BE USED WITHOUT WRITTEN PERMISSION		DOCUMENT NO. SD-74736-210						