

ABSOLUTE MAXIMUM RATINGS <sup>2</sup>

SUPPLY VOLTAGE	+30V CONTINUOUS
VOLTAGE EXTERNALLY APPLIED TO OUTPUT	-0.5 TO +30V (OUTPUT HIGH)
OUTPUT CURRENT	40 mA SINKING

RECOMMENDED OPERATING CONDITIONS

PARAMETER	CONDITIONS	MIN	TYP	MAX	UNITS
OPERATING TEMPERATURE		-40		+150	°C <sup>9</sup>
SUPPLY VOLTAGE		4.5		24	VDC
SUPPLY CURRENT I <sub>cc</sub>			10	20	mA
V <sub>sat</sub>	LOW OUTPUT			.4	VDC
OUTPUT CURRENT	LOW OUTPUT			20	mA
OUTPUT LEAKAGE CURRENT	HIGH OUTPUT			10	μA
RISE TIME	10% TO 90%			15	μS
FALL TIME	90% TO 10%			1.0	μS

OPERATING SPECIFICATIONS <sup>3 8</sup>

	LIMIT	CONDITIONS	UNITS
<sup>4</sup> OPERATE	3.3° ± 1.25°	AIR GAP 0.13-2.03	mm
<sup>5</sup> RELEASE	4.4° ± 2.5°	V <sub>SUPPLY</sub> 4.5 - 24	VOLTS
		TEMP -40 TO 150	DEG. C
		RPM 10 TO 5000	

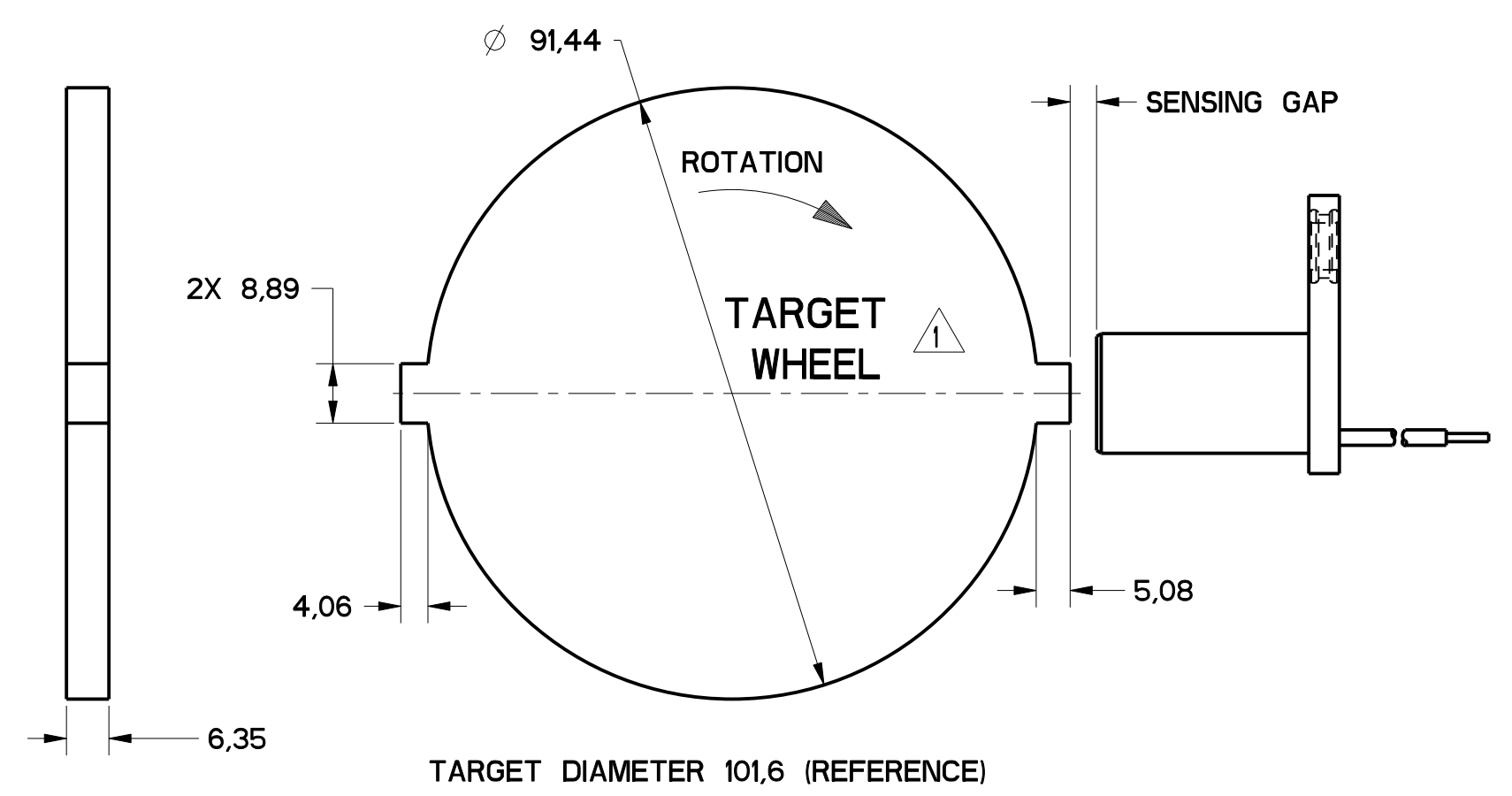
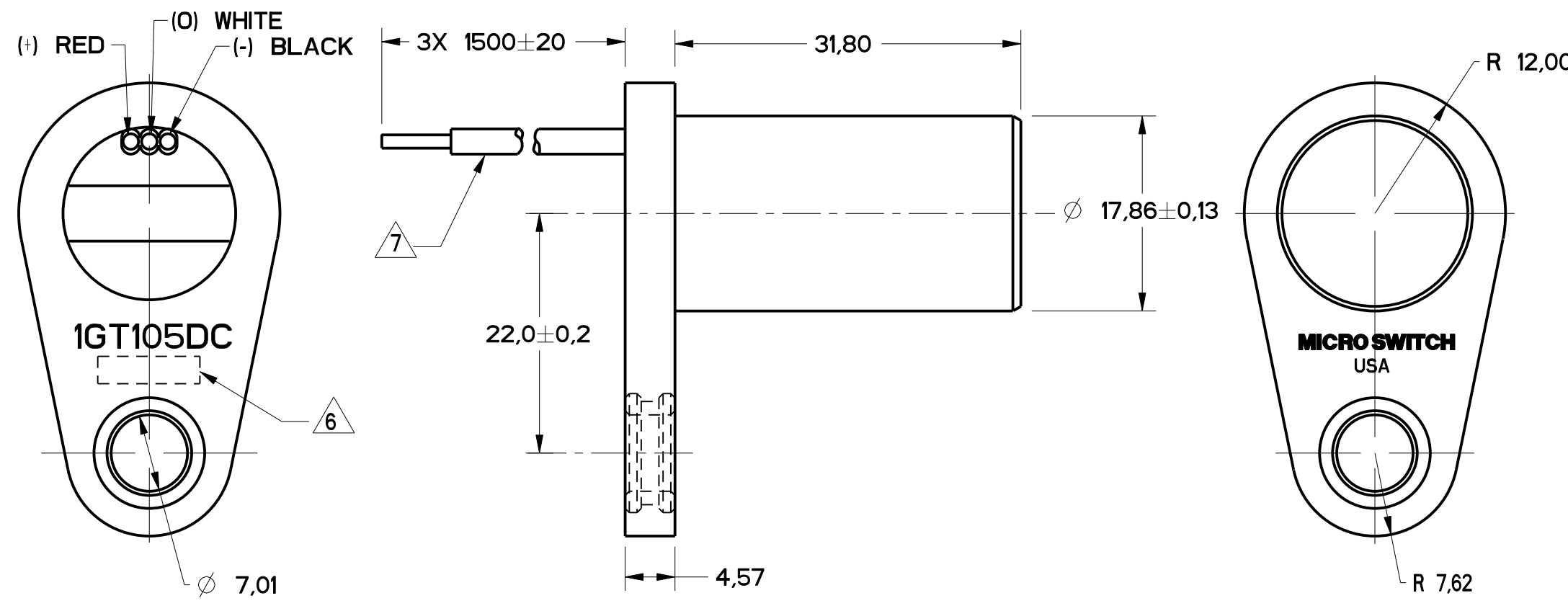
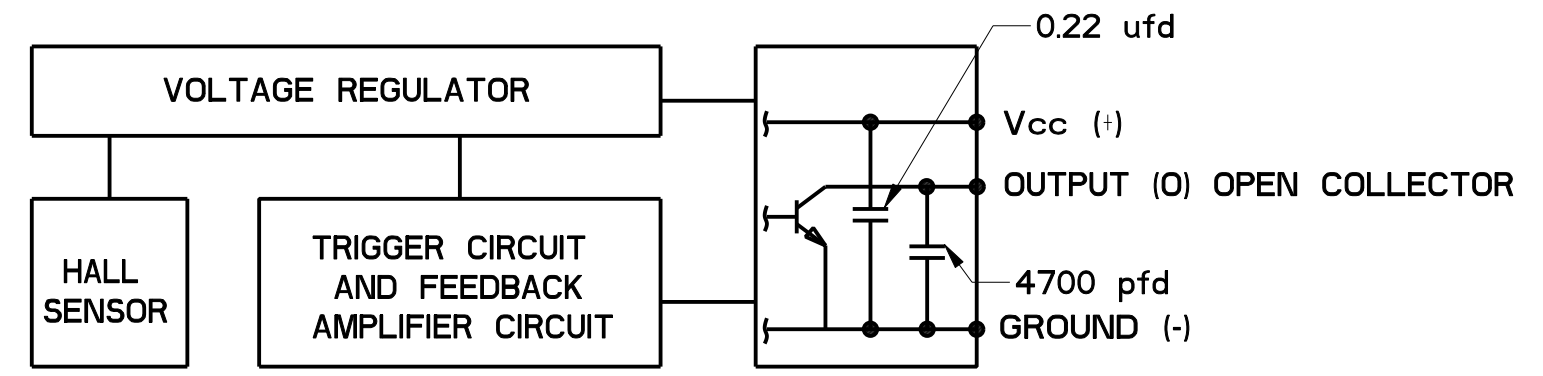

FIGURE 1



NOTES

- <sup>1</sup> TARGET SHOULD BE MADE OF GOOD MAGNETIC MATERIAL (C-1018), ANNEAL AFTER MACHINING OR FORMING
- <sup>2</sup> MAXIMUM LIMITS THAT SWITCH WILL WITHSTAND WITHOUT DAMAGE
- <sup>3</sup> OPERATING SPECIFICATION IS BASED ON TARGET SHOWN IN FIGURE 1 AND WILL VARY WITH TARGET GEOMETRY
- <sup>4</sup> OPERATE (DEGREES) IS THE ANGULAR DISTANCE FROM THE LEADING EDGE OF THE TOOTH TO THE CENTERLINE OF THE SENSOR
- <sup>5</sup> RELEASE (DEGREES) IS THE ANGULAR DISTANCE FROM THE TRAILING EDGE OF THE TOOTH TO THE CENTERLINE OF THE SENSOR
- <sup>6</sup> DATE CODE YYWW THIS AREA
- <sup>7</sup> 22 GAUGE WIRE, CROSSLINKED POLYETHYLENE INSULATION
- <sup>8</sup> ELECTRICAL CHARACTERISTICS GUARANTEED WITH MAX EXTERNAL LOAD CAPACITANCE ≤ 550 pfd
- <sup>9</sup> OPERATING TEMPERATURE APPLIES TO SENSOR ONLY, WIRE IS RATED TO 135°C
- 10 RoHS COMPLIANT



BLOCK DIAGRAM SHOWING CURRENT SINKING OUTPUT



THIRD ANGLE PROJECTION
SCALE 2:1
DO NOT SCALE PRINT
UNLESS OTHERWISE SPECIFIED TOLERANCES ARE
NO PLACE (0) ± 1 MM
ONE PLACE (0,0) ± 0,4 MM
TWO PLACE (0,00) ± 0,15 MM
ANGLES ±
WEIGHT

1GT105DC  
 DRAWING NUMBER  
 PAGE 1 OF 1  
 RELEASE NO. PR-23897  
 REPLACES  
 ISSUE 3  
 REVISIONS  
 A 204349  
 REV 9 NOV 01  
 B 21332  
 REV 11 MAY 06  
 PTC/CAD 2D  
 J A F 03SEP99  
 CHECK SAV  
 03SEP99  
 CHECK